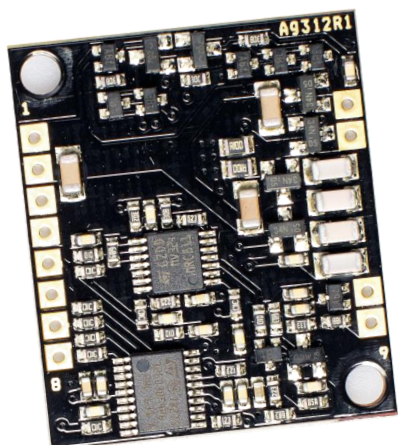




# Ag312

Wireless Power Module



## Features

- Qi Compatible (A5 / A11)
- Low Standby Current
- Size 33.12mm x 28.65mm x 5.1mm
- Simple Integration

## Description

The Ag312 is a wireless power transmitter (A5 / A11) module; designed to work with the Ag301 or any other Qi compliant wireless power receiver, typically used in wireless charging applications.

With the increased use of mobile & portable devices, the Ag301 & Ag312 wireless power modules offer a wide range of benefits: -

There are no cables to get tangled and you don't have the problem of having different plugs or sockets for various devices. There is no risk of electrical shock, as there are no exposed metal parts. Can be used in explosive environments as there are no contacts to cause sparks. This means that there is no contact degradation due to friction, corrosion or abrasion. The units can be completely sealed for use in harsh environments, as its operation is not affected by dirt, dust, water or chemicals and can even be used underwater. Can be used in medical environment where disinfecting and sterilization is required.

## Table of Contents

<b>1</b>	<b>Product Overview .....</b>	<b>3</b>
1.1	Ag312 Product Selector .....	3
1.2	Purchasing Options: .....	3
1.3	Package Format .....	4
1.4	Pin Description .....	4
<b>2</b>	<b>Functional Description .....</b>	<b>5</b>
2.1	Wireless Power Overview .....	5
2.2	Coils and Alignment .....	6
2.1	Input Power Supply .....	8
2.2	Shutdown Input .....	8
2.1	Status Outputs.....	9
<b>3</b>	<b>Typical Connections .....</b>	<b>10</b>
<b>4</b>	<b>Typical Applications .....</b>	<b>10</b>
<b>5</b>	<b>Operating Temperature .....</b>	<b>11</b>
<b>6</b>	<b>Protection .....</b>	<b>11</b>
6.1	Input Protection .....	11
<b>7</b>	<b>Electrical Characteristics .....</b>	<b>12</b>
7.1	Absolute Maximum Ratings.....	12
7.2	Recommended Operating Conditions .....	12
7.3	DC Electrical Characteristics.....	12
<b>8</b>	<b>Package.....</b>	<b>13</b>

## Table of Figures

Figure 1:	Block Diagram .....	3
Figure 2:	Ag312 Package Format.....	4
Figure 3:	Charger Overview.....	5
Figure 4:	Horizontal View.....	6
Figure 5:	Vertical View.....	6
Figure 6:	X Offset.....	7
Figure 7:	Y Offset.....	7
Figure 8:	Control Inputs .....	8
Figure 9:	Status Outputs .....	9
Figure 10:	Typical Application Drawing .....	10
Figure 11:	Ag312 Operating Temperature Profile .....	11
Figure 12:	Package Dimensions.....	13

## 1 Product Overview

### 1.1 Ag312 Product Selector

Part Number <sup>1</sup>	Input Voltage	Type	Package	Date code <sup>2</sup> Marking
Ag312	5V	Transmitter	DIL	WW/YY

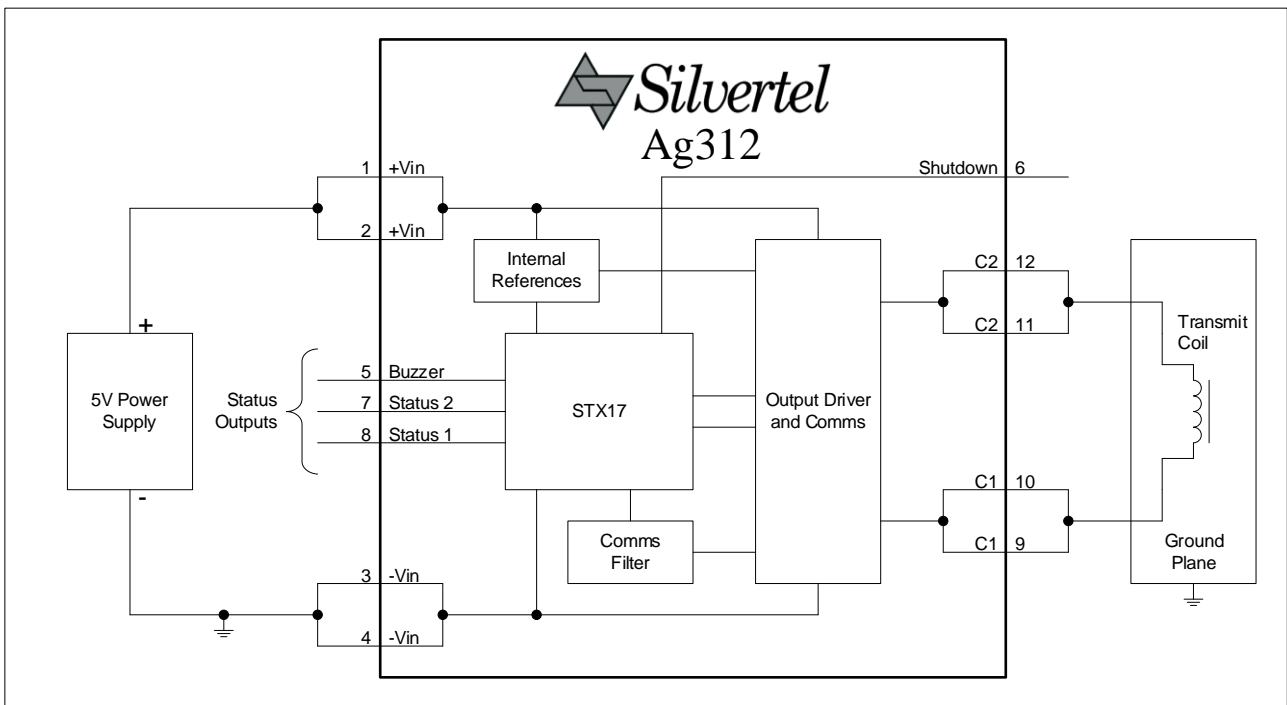
Note 1: Complies with the European Directive 2011/65/EU for the Restriction of use of certain Hazardous Substances (RoHS) including Directive 2015/863 published in 2015, amending Annex II of Directive 2011/65/EU. Moisture Sensitive Level 1 and HBM 1.

Note 2: Date code format: "WW" = Week Number, "YY" = Year.

**Table 1: Ordering Information**

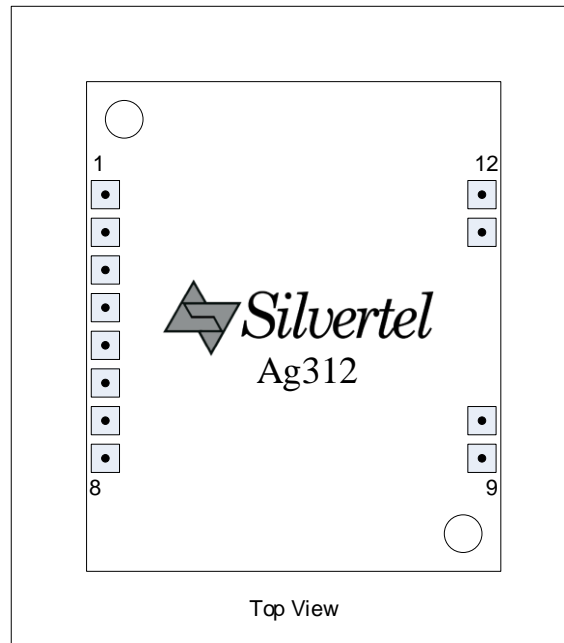
### 1.2 Purchasing Options:

Large volume customers of typically 100K+ can purchase the STX17 controller IC on its own and Silvertel will supply the applications circuit so the customer can assemble it themselves



**Figure 1: Block Diagram**

### 1.3 Package Format



**Figure 2: Ag312 Package Format**

### 1.4 Pin Description

Pin	Name	Description
1	+Vin	<b>5V (Supply).</b> These pins connect to an external +5V power supply rail.
2		
3	-Vin	<b>0V (Supply).</b> These pins connect to the 0V return rail of the input power supply.
4		
5	Buzzer	<b>Buzzer (Output).</b> This pin can be connected to an external buzzer (as shown in Figure 10).
6	Shutdown	<b>Shutdown (Input).</b> Pulling this input low, will stop the Ag312 transmitting power. This pin has an internal pull up to a +3.3V rail.
7	Status 2	<b>Status (Outputs).</b> These pins indicate the status of the Ag312.
8	Status 1	
9	C1	<b>Output Coil.</b> These pins connect to the transmitter coil.
10		
11	C2	<b>Coil Return.</b> These pins connect to return of the transmitter coil.
12		

**Table 2: Pin Description**

## 2 Functional Description

### 2.1 Wireless Power Overview

When the Ag312 wireless transmitter is connected to a 5V supply, it will start up and will commence looking for an Ag301 (or Qi Compatible) wireless receiver in range.

It does this by applying a short power signal to the transmit coil to detect an object. If an object is detected then this signal is extended, looking for a “Ping” data message back from the receiver.

If a valid “Ping” message is not received, the transmitter will remove the power signal and wait ~500ms before repeating the above process.

If a valid “Ping” message is received, the power signal is maintained and the transmitter looks for the “Identification & Configuration” message and the “Power Transfer” message.

If either the “Identification & Configuration” or the “Power Transfer” messages are invalid, the transmitter will remove the power signal and wait ~500ms before repeating the above steps.

If the transmitter receives valid data, it will maintain and adjust the power signal in accordance with the data sent back from the receiver. The Status 1 output will go to logic 1 and the Buzzer output pin will go to logic 1 for ~500ms, indicating that the power transfer has started.

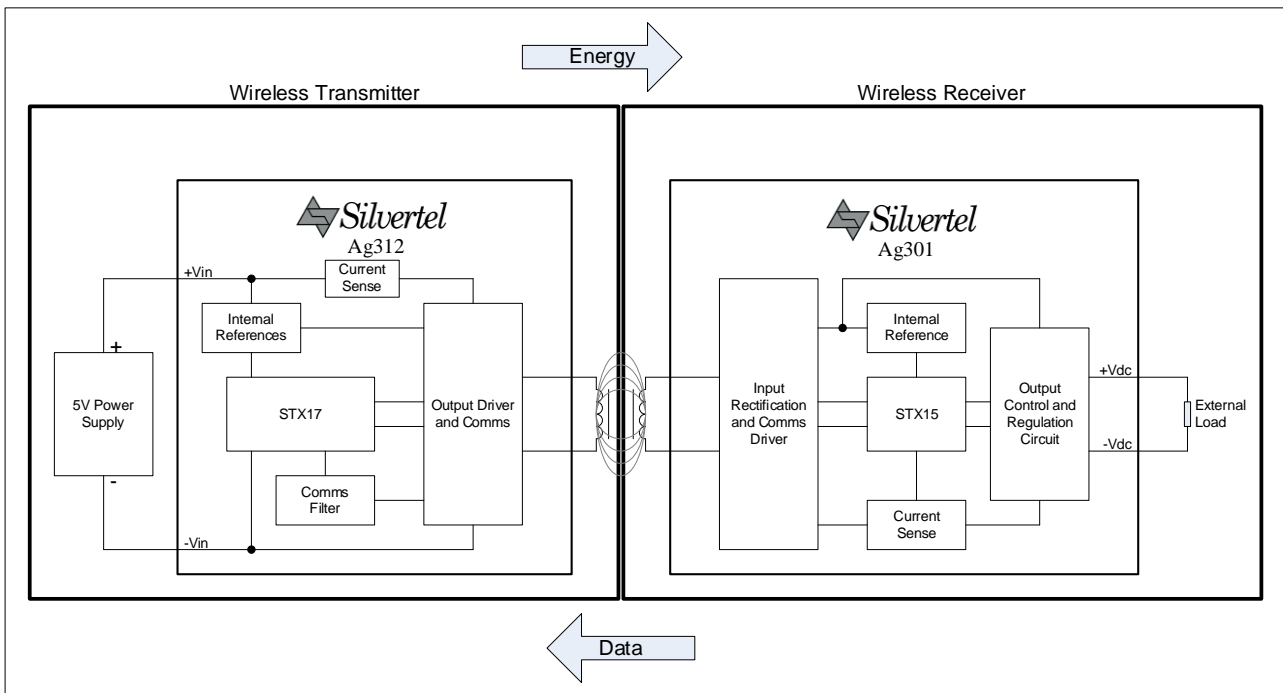


Figure 3: Charger Overview

## 2.2 Coils and Alignment

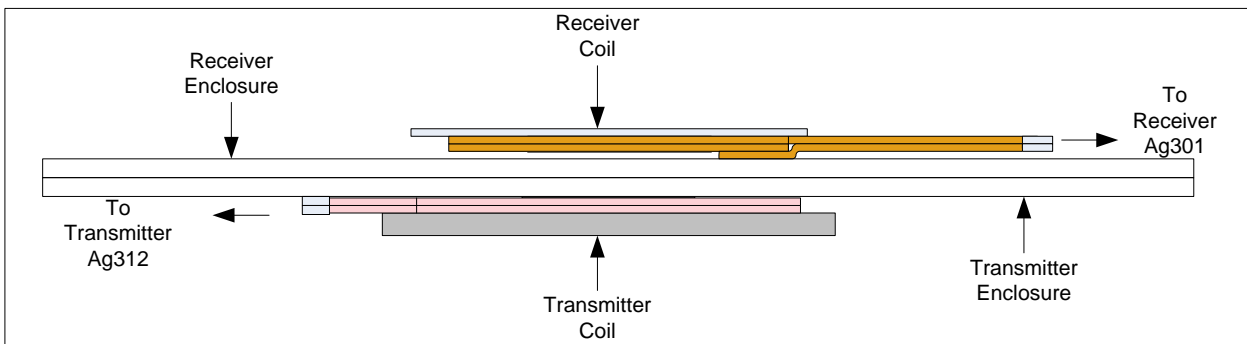
The wireless power connection is established through transmit and receive coils. For the Ag312 we recommend the following (or equivalent) coil: -

TYPE	WURTH	ELYTONE ELECTRONIC CO.
A5	760308105	ETW-00032
A11 (circular)	760308111 760308100111	ETW-00032W

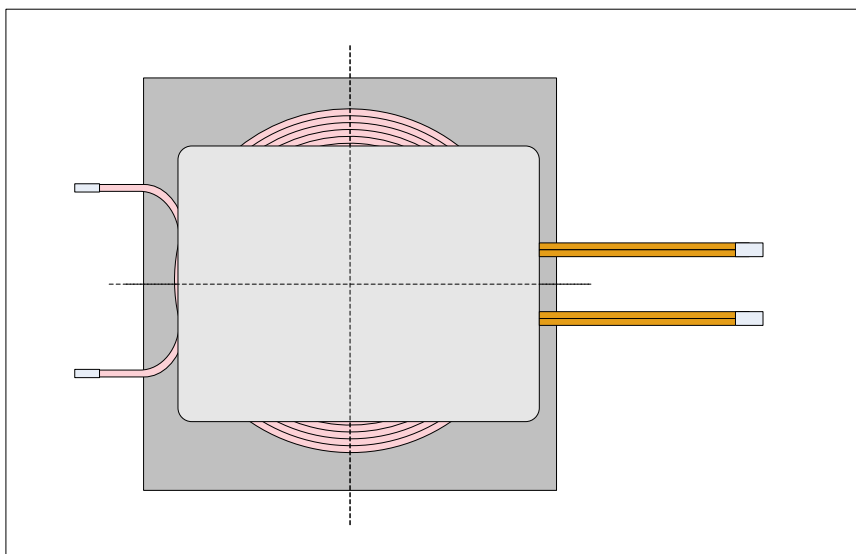
**Table 3: Recommended Coils**

The nominal alignment position of the coils is shown below in Figures 4 and 5

In Figure 4 you can see that the coils are separated by the transmitter and receiver enclosures. The Qi specification allows the transmitter enclosure thickness to be between 1.75mm to 2.5mm, and the receiver enclosure thickness to be between 0mm to 2.5mm. The Ag312 has been designed to meet this specification and the Ag301 is capable of operating well beyond the 2.5mm specification.

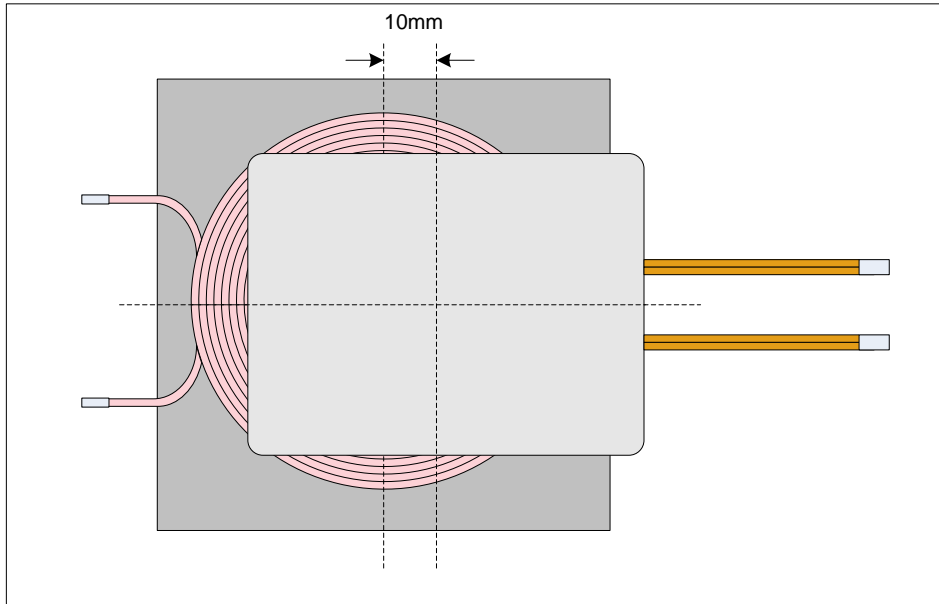


**Figure 4: Horizontal View**

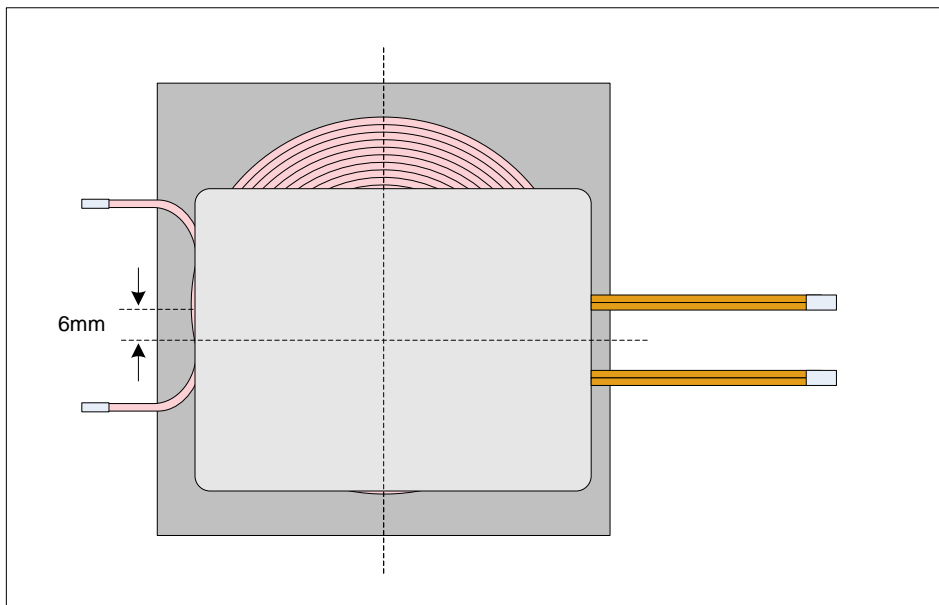


**Figure 5: Vertical View**

Figure 5 shows the Ag301 and Ag312 coils perfectly centred, which is the optimum position for power and data transfer. But the Ag301 and Ag312 will operate if the coils are not perfectly centred. Figures 6 and 7 shows the amount the coils can be offset, still allowing the Ag301 and Ag312 to start up even at full load.



**Figure 6: X Offset**



**Figure 7: Y Offset**

Once the Ag301 is fully up and running, the X Offset can be increased to ~20mm or the Y Offset increased to ~17mm.

## 2.1 Input Power Supply

It is important that the input power supply used, is a stable regulated 5V supply with low ripple. It is also very important that the voltage drop between the power supply output and the Ag312 input is kept as low as possible. Using a low quality power supply or high resistance connections can cause operational stability issues. This may result in additional ripple on the output of the receiver, or no operation at all.

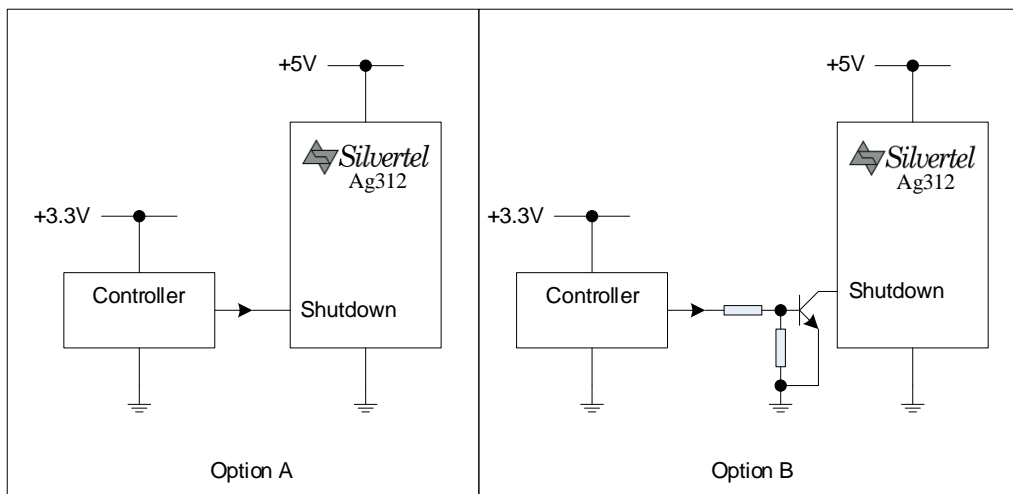
To ensure that you can get the maximum available power from the receiver, it is important that the input supply has sufficient power (see Section 7.3). The Ag312 will work with a limited power supply, but if the load tries to draw too much power the Ag312 will shut down.

## 2.2 Shutdown Input

The Ag312 has an optional control input: – Shutdown.

This input has an internal pull-up to a +3.3V reference. It can be driven directly from a controller (or logic gate) that has a +3.3V rail, or via an external transistor if the external rail is not +3.3V (see Figure 8).

It is important that if Figure 8 “Option A” is used, that the controller output is tri-state or high at start-up. If this is an issue then “Option B” may be a better solution. The transistor does not need to be anything special and the resistors can be high values (100KΩ).



**Figure 8: Control Inputs**

When this input is pulled low, the Ag312 will stop sending power and enter into error mode.

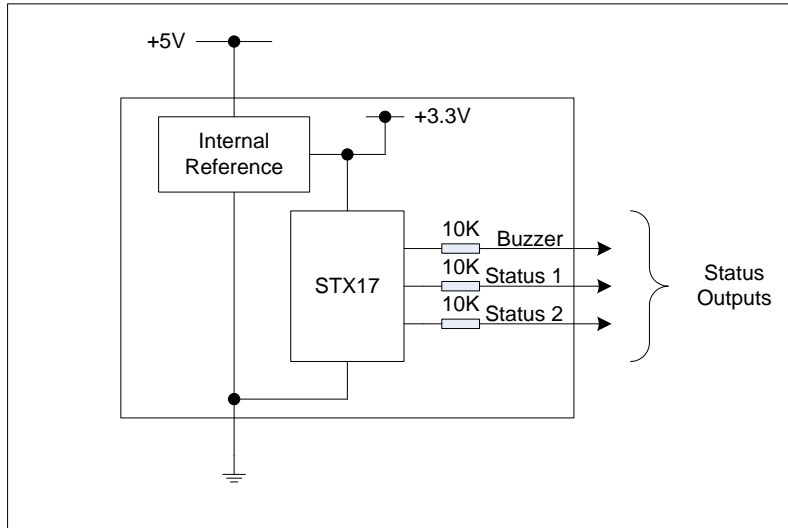
One of the applications where the Shutdown input can be used is for thermal protection. With one or more thermistors (thermally) connected to the coil, a controller could monitor the temperature and disable the Ag312 if the temperature gets too high.



## 2.1 Status Outputs

The Ag312 module has three status output pins – Buzzer, Status 1 and Status 2.

These outputs are all driven from an internal +3.3V reference and are limited with an internal 10K series resistor (see Figure 9).



**Figure 9: Status Outputs**

### 2.1.1 Buzzer

On successful completion for the start-up communication protocol (as detailed in Section 2.1), this output will go to logic 1 (with reference to the internal +3.3V rail, shown in Figure 9) for a duration of ~500ms. This output can be connected to a Piezoelectric buzzer (as shown in Figure 10) to give an audible indication that the Ag312 has started to supply power to a receiver.

### 2.1.2 Status 1 & 2

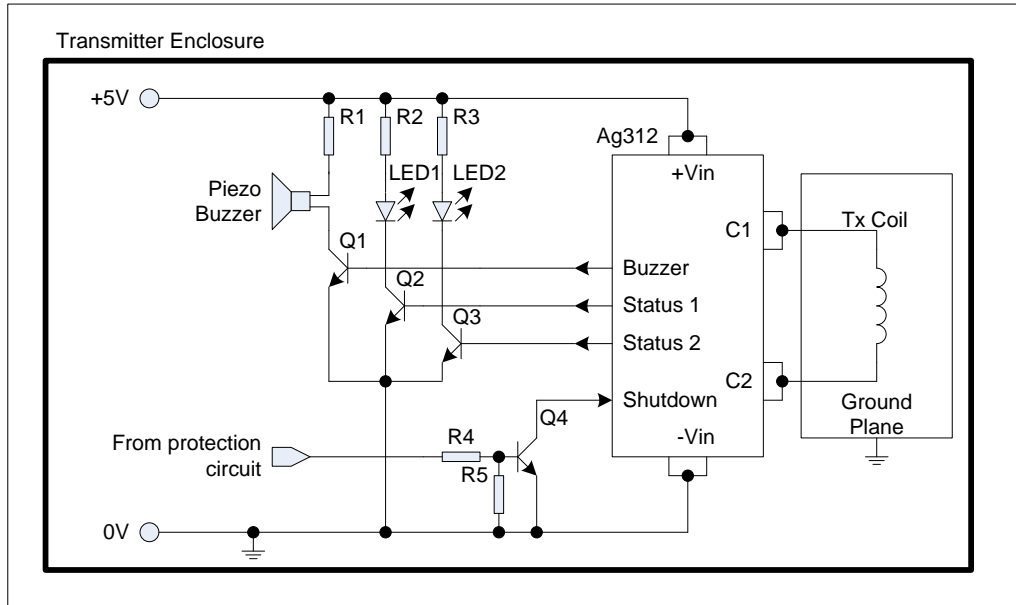
The two Status output pins indicate the operational condition of the Ag312. Table 4 shows the output logic state of these outputs. Logic 1 is referenced to the internal +3.3V rail and current limited by the internal 10K series resistors (as shown in Figure 9).

Ag312 Status	Status 1 Output	Status 2 Output
Idle	0	0
Charging	1	0
Error	0	1
Charge Complete	1	1

**Table 4: Status 1 & 2**

### 3 Typical Connections

The Ag312 is very easy to implement, Figure 10 shows typical application drawing, giving a basic overview.



**Figure 10: Typical Application Drawing**

### 4 Typical Applications

The Ag312 can be used in a wide range of wireless power and charging applications and with the increased use of mobile & portable devices this list is expanding every day.

At present one of the biggest market sectors for wireless charging are in mobile phones.

But there are many more applications that can benefit from the advantages of wireless power transfer.

Because there are no contacts to cause sparks, wireless charging can be used in environments where combustible materials or gases are present.

Also as the transmitter and receiver can be built into completely sealed enclosures; they can be used in harsh environments, where dust, dirt, water or chemicals are present.

On the other end of the spectrum, wireless power also lends itself for use in clean environments, where disinfecting and sterilization is required.

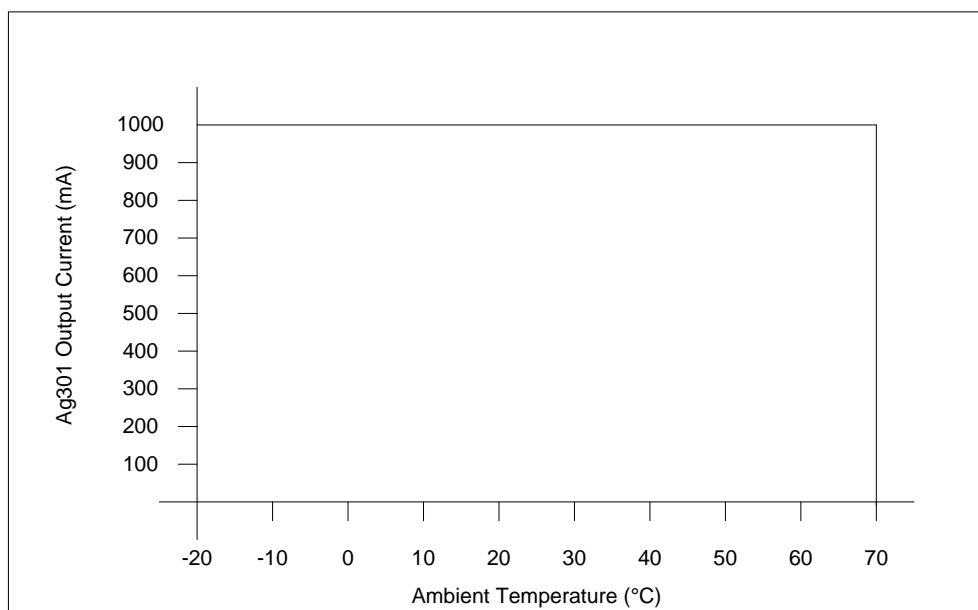
## 5 Operating Temperature

The Ag312 has to drive the output transmission coil, this process does cause the module to generate heat and as a result this will need to be taken into consideration.

The amount of heat generated by the module is primarily related to the current being drawn by the receiver. So care needs to be taken to control the ambient temperature around the module.

The Ag312 has a maximum ambient operating temperature of 70°C. These results were performed in an environmental chamber (Associated Environmental Systems – SD-302), without any heat-sinking.

The results shown in Figure 11 are relative to the output power drawn from an Ag301 receiver (used to load the Ag312).



**Figure 11: Ag312 Operating Temperature Profile**

## 6 Protection

### 6.1 Input Protection

To protect the Ag312 input from any over-voltage transients; we recommend fitting a SMAJ5A directly across the power supply input pins (+Vin and –Vin).

## 7 Electrical Characteristics

### 7.1 Absolute Maximum Ratings

	Parameter	Symbol	Min	Max	Units
1	Storage Temperature	$T_S$	-40	+100	°C
2	DC Supply Voltage Surge for 1ms	$V_{SURGE}$	-0.3	25	V
3	Shutdown Input Maximum DC Rating	$V_{SMAX}$	-0.3	3.5	V

Note: Exceeding the above ratings may cause permanent damage to the product. Functional operation under these conditions is not implied. Maximum ratings assume free airflow.

### 7.2 Recommended Operating Conditions

	Parameter	Symbol	Min	Typ	Max	Units
1	Operating Temperature	$T_{OP}$	-20	25	70 <sup>1</sup>	Ta / °C
2	Input Voltage Range	$V_{IN}$	4.75		5.25	V

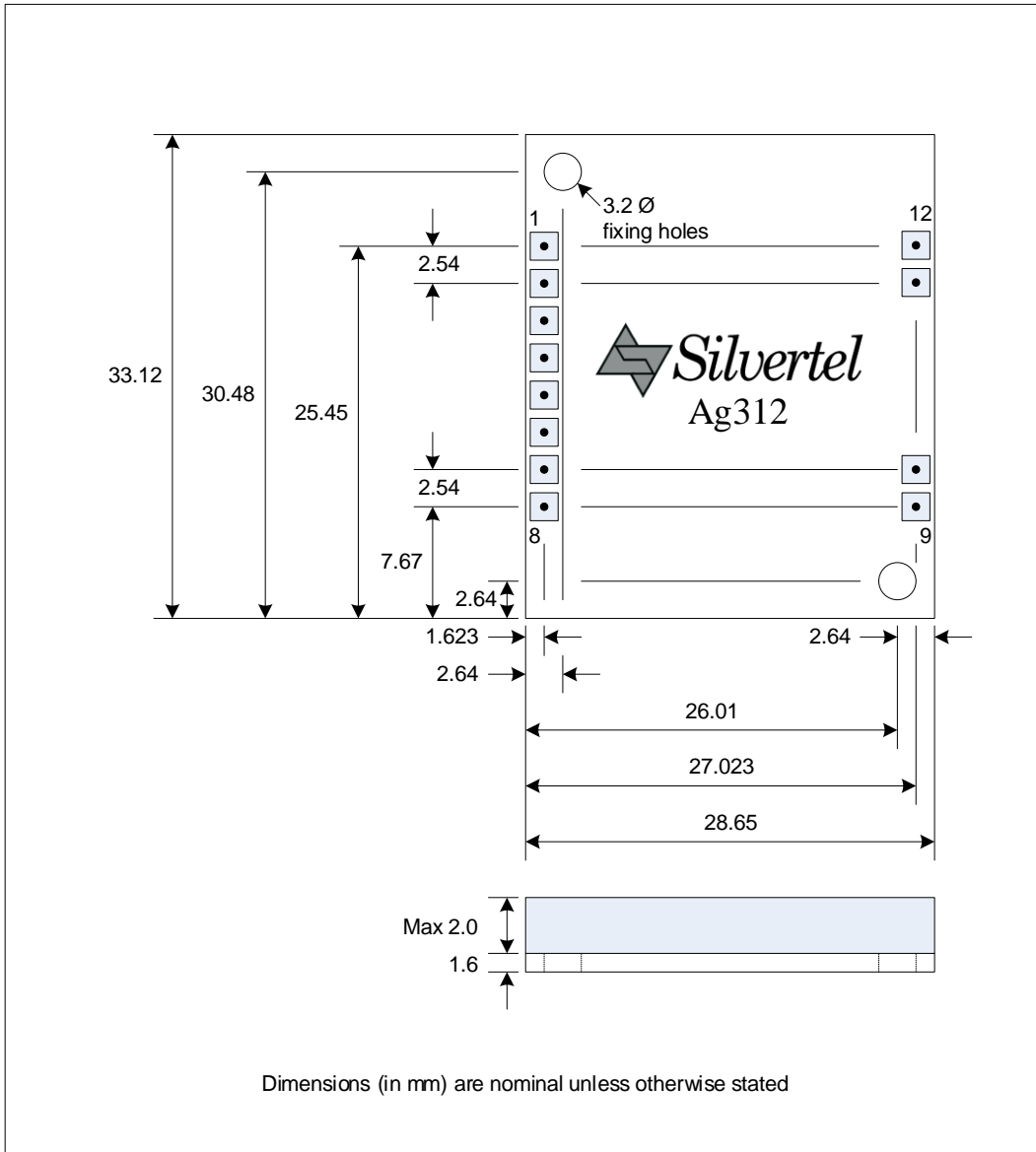
Note 1: See Section 5

### 7.3 DC Electrical Characteristics

	DC Characteristic	Sym	Min	Typ <sup>1</sup>	Max	Units	Test Comments
1	Input Voltage	$V_{IN}$		5		V	
2	Input Current - Idle	$I_{IDLE}$		8.5		mA	
3	Input Current - Max Load	$I_{ML}$		1700		mA	With TI RX Load = 1A
4	Peak Efficiency	EFF		71.15		%	With TI RX
5	Maximum Start Up Distance Between Coils	$D_{ST}$		11.5		mm	@ Full Load with TI RX
6	Maximum Operating Distance Between Coils	$D_{OP}$		12.3		mm	@ Full Load with TI RX
7	Shutdown Input Logic Low Voltage	$V_{IL}$			0.75	V	
8	Shutdown Input Logic High Voltage	$V_{IH}$	2.25			V	

Note 1: Typical figures are at 25°C and are for design aid only. Not Guaranteed.

**8 Package**



**Figure 12: Package Dimensions**

Information published in this datasheet is believed to be correct and accurate. Silver Telecom assumes no liability for errors which may occur or for liability otherwise arising out of use of this information or infringement of patents which may occur as a result of such use. No license is granted by this document under patents owned by Silver Telecom or licensed from third parties by Silver Telecom. The products, their specification and information appearing in this document are subject to change by Silver Telecom without notice.