

Spezifikation für Freigabe / specification for release

Kunde / customer :
 Artikelnummer / part number : **749013011A**
 Bezeichnung : **LAN-Übertrager WE-LAN PoE**
 description : **LAN-Transformer WE-LAN PoE**



DATUM / DATE : 2014-01-08

A Mechanische Abmessungen / dimensions :

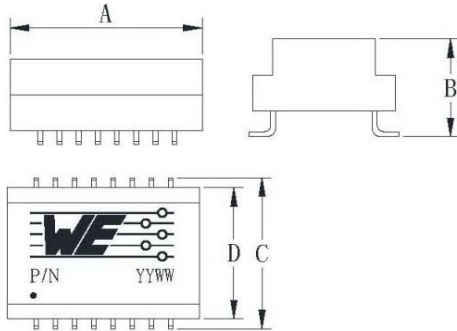

	100 BaseT PoE	
A	12,70 ± 0,25	mm
B	6,35 max.	mm
C	9,40 ± 0,25	mm
D	8,80 ± 0,25	mm

● = Pin 1

B Elektrische Eigenschaften / electrical properties :

Eigenschaften / properties	Testbedingungen / test conditions		Wert / value	Einheit / unit	tol.
Induktivität / Inductance	100kHz / 100mV @ 8mA DC-Bias	OCL	350	µH	min.
Übersetzungsverhältnis / Turns ratio	100kHz / 100mV	TR	1 : 1	Tx	3%
			1 : 1	Rx	
Insertion Loss	1-100MHz	IL	-1,1	dB	max.
Return Loss	1-30MHz @ 100Ω	RL	-18	dB	min.
	30-60MHz @ 100Ω		-14		
	60-80MHz @ 100Ω		-12		
	80-100MHz @ 100Ω		-10		
Differential to Common Mode Rejection	30MHz	DCMR	-38	dB	min.
	60MHz		-38		
	100MHz		-30		
Crosstalk	60MHz	CT	-40	dB	min.
	100MHz		-35		

C Lötpad / soldering spec. :

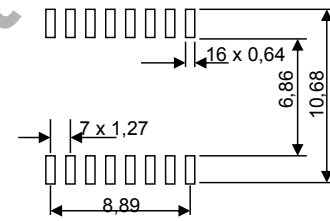

D Prüfgeräte / test equipment :

HP-4284 CH-19073
 HP-8714 CH-3250

E Testbedingungen / test conditions :

Luftfeuchtigkeit / humidity: 33%
 Umgebungstemperatur / temperature: +25°C

F Werkstoffe & Zulassungen / material & approvals :

Basismaterial / base material: Ferrit/ ferrite
 Draht / wire: 0UEW QPN200
 Kontaktmaterial/ contact plating: Cu-Ni-Sn
 Gehäuse/ case Bakelite & UL94-V0

G Eigenschaften / general specifications :

Betriebstemp. / operating temperature: -40°C - + 85°C
 Hochspannungsprüfung / Hipot test: 1500Vrms 1min.
 Komplanarität: < 0,1 mm / Coplanarity: < 0,1 mm
 Geeignet für 10/100Base-TX gemäß IEEE 802.3af /
 Compliant with IEEE 802.3af for 10/100Base-TX-Applications
 Auto MDIX fähig / Auto MDIX capable

Freigabe erteilt / general release:

	Kunde / customer		
.....	MLe	Version 04 2014-01-08
Datum / date	Unterschrift / signature	MLe	Version 03 2013-08-01
.....	MLe	Version 02 2013-05-08
.....	MLe	Version 01 2013-02-14
.....	MLe	Version 00 Preliminary 2012-11-09
Geprüft / checked	Kontrolliert / approved	Name	Änderung / modification Datum / date

Würth Elektronik eiSos GmbH & Co.KG

D-74638 Waldenburg · Max-Eyth-Straße 1 - 3 · Germany · Telefon (+49) (0) 7942 - 945 - 0 · Telefax (+49) (0) 7942 - 945 - 400
<http://www.we-online.com>

Spezifikation für Freigabe / specification for release

Kunde / customer :
 Artikelnummer / part number : **749013011A**
 Bezeichnung : LAN-Übertrager WE-LAN PoE
 description : LAN-Transformer WE-LAN PoE



DATUM / DATE : 2014-01-08

H Schaltbild / Schematics :

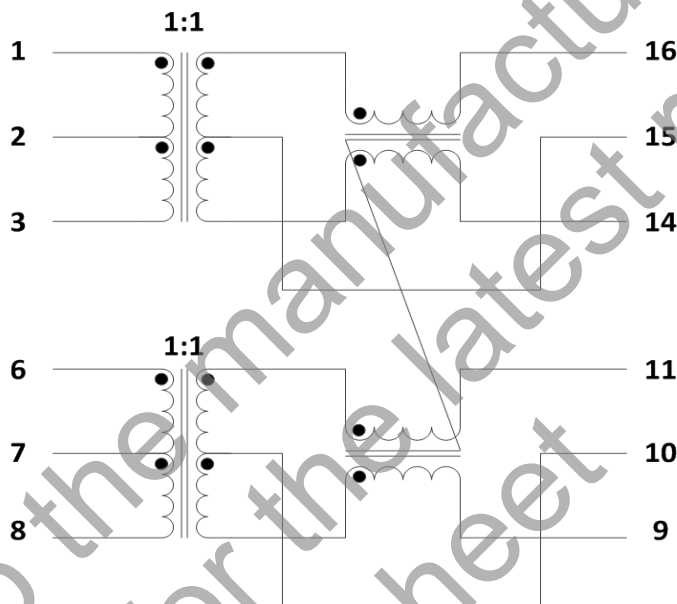

Refer to the manufacturer's website for the latest revision of this datasheet

Freigabe erteilt / general release:	Kunde / customer			
Datum / date	Unterschrift / signature	MLe	Version 04	2014-01-08
	Würth Elektronik	MLe	Version 03	2013-08-01
		MLe	Version 02	2013-05-08
		MLe	Version 01	2013-02-14
		MLe	Version 00 Preliminary	2012-11-09
Geprüft / checked	Kontrolliert / approved	Name	Änderung / modification	Datum / date

Würth Elektronik eiSos GmbH & Co.KG

D-74638 Waldenburg · Max-Eyth-Straße 1 - 3 · Germany · Telefon (+49) (0) 7942 - 945 - 0 · Telefax (+49) (0) 7942 - 945 - 400
<http://www.we-online.com>

Spezifikation für Freigabe / specification for release

Kunde / customer :
 Artikelnummer / part number : **749013011A**
 Bezeichnung : **LAN-Übertrager WE-LAN PoE**
 description : **LAN-Transformer WE-LAN PoE**



DATUM / DATE : 2014-01-08

I Rollenspezifikation / tape and reel specification :

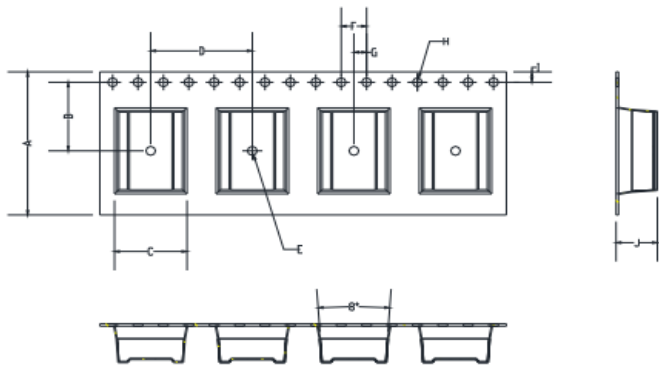

Gurtspezifikation / Tape specification:		
A	24,00 ± 0,1	mm
B	11,50 ± 0,1	mm
C	11,42 ± 0,1	mm
D	16,00 ± 0,1	mm
E	1,50 ± 0,1	mm
F	4,00 ± 0,1	mm
G	2,00 ± 0,1	mm
H	1,50 ± 0,1	mm
I	1,75 ± 0,1	mm
J	6,52 ± 0,1	mm

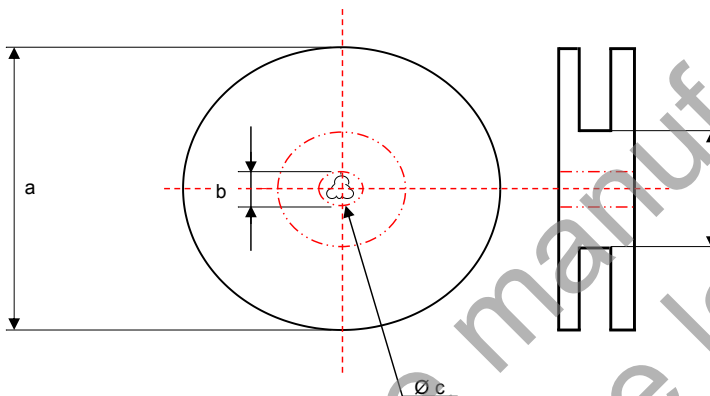

Rollenspezifikation / Reel specification:		
a	330,0 ± 2,0	mm
b	21,00 ± 0,8	mm
c	13,50 ± 0,5	mm
d	100,0 ± 1,0	mm

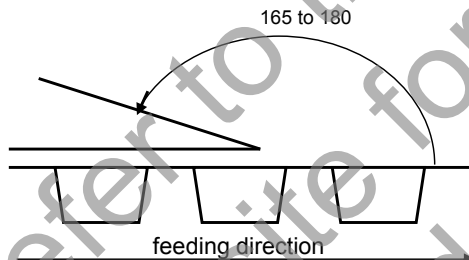

The force for tearing off cover tape is 40 to 120 grams in arrow direction

Freigabe erteilt / general release:	Kunde / customer		
Datum / date	Unterschrift / signature	MLe	Version 04 2014-01-08
	Würth Elektronik	MLe	Version 03 2013-08-01
		MLe	Version 02 2013-05-08
		MLe	Version 01 2013-02-14
		MLe	Version 00 Preliminary 2012-11-09
Geprüft / checked	Kontrolliert / approved	Name	Änderung / modification Datum / date

This electronic component has been designed and developed for usage in general electronic equipment. Before incorporating this component into any equipment where higher safety and reliability is especially required or if there is the possibility of direct damage or injury to human body, for example in the range of aerospace, aviation, nuclear control, submarine, transportation, (automotive control, train control, ship control), transportation signal, disaster prevention, medical, public information network etc. Würth Elektronik eiSos GmbH must be informed before the design-in stage. In addition, sufficient reliability evaluation checks for safety must be performed on every electronic component which is used in electrical circuits that require high safety and reliability functions or performance.

Würth Elektronik eiSos GmbH & Co.KG

D-74638 Waldenburg · Max-Eyth-Straße 1 - 3 · Germany · Telefon (+49) (0) 7942 - 945 - 0 · Telefax (+49) (0) 7942 - 945 - 400
<http://www.we-online.com>