

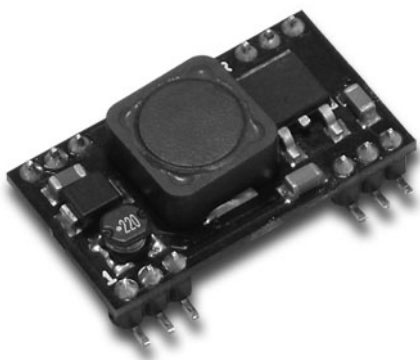

Ag8100

Power-Over-Ethernet Module



1 Features

- IEEE802.3af compliant
- Small surface mount package size – 32mm (L) x 18mm (W) x 11.5mm (H)
- High efficiency DC/DC converter
- Input voltage range 37V to 57V
- Overload and short-circuit protection
- Adjustable Output - 3 product variants cover all voltages from 2.5V to 14V
- Thermal Cut Off
- Silvertel “design-in” assistance

2 Description

The Ag8100 series of modules are designed to extract power from a conventional twisted pair Category 5 Ethernet cable, conforming to the IEEE 802.3af Power-over-Ethernet (PoE) standard.

The Ag8100 signature and control circuit provides the PoE compatibility signature and power classification required by the Power Sourcing Equipment (PSE) before applying up to 15W power to the port. The Ag8100 is compatible with Class 0 to Class 3 equipment.

The high efficiency DC/DC converter operates over a wide input voltage range and provides a non-isolated regulated low ripple and low noise output. The DC/DC converter also has built-in output overload, output short-circuit and over-temperature protection.

2.1 Table of Contents

1	Features	1
2	Description.....	1
3	Ag8100 Product Selector.....	3
4	Pin Description	4
5	Functional Description	6
5.1	Inputs.....	6
5.2	PD Signature	6
5.3	Isolation	6
5.4	Power Classification	7
5.5	DC/DC Converter	7
5.6	Grounding.....	8
5.7	Output Adjustment.....	8
5.8	Typical Connections	9
6	Typical Application.....	10
7	Typical Recommendations	11
8	Operating Temperature Range	11
9	Protection	15
10	Electrical Characteristics.....	16
10.1	Absolute Maximum Ratings*.....	16
10.2	Recommended Operating Conditions.....	16
10.3	DC Electrical Characteristics*	16
11	Package	17

2.2 Table of Figures

Figure 1: Block Diagram with External Components.....	3
Figure 2: Ag8100 SMT Package Format.....	5
Figure 3: Typical System Diagram.....	6
Figure 4: Class Programming Option.....	7
Figure 5: Output Adjustment	8
Figure 6: Typical Connection Diagram.....	9
Figure 7: Typical Application.....	10
Figure 8: Typical Layout.....	11
Figure 9: Power Plane Heatsink for Ag8100	12
Figure 10: Ag8103 Operating Profile	12
Figure 11: Ag8105 Operating Profile	13
Figure 12: Ag8112 Operating Profile	13

3 Ag8100 Product Selector

Part Number†	Nominal Output Voltage	Maximum Output Power *	Marking	Package
Ag8112-M	12.0V	12 Watts	12	SMT
Ag8105-M	5.0V	7 Watts	5	SMT
Ag8103-M	3.3V	5.25 Watts	3	SMT

*At 25°C with $V_{IN} = 48V$

† All versions of the Ag8100 fully meet the requirements of the RoHS directive 2002/95/EC on the restriction of hazardous substances in electronic equipment.

Table 1: Ordering Information

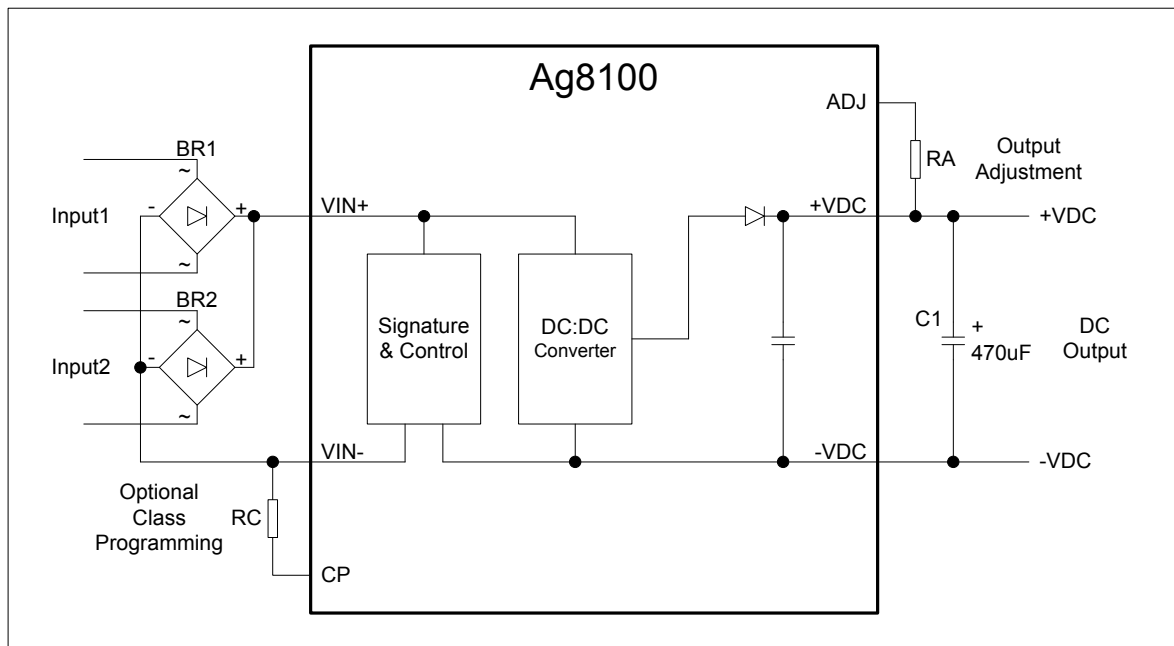

Figure 1: Block Diagram with External Components

4 Pin Description

Pin #	Name	Description
1	+VDC	Positive DC Output. These pins provide the positive regulated output from the DC/DC converter.
2		
3		
4	CP	Class Programming. Connecting an external resistor to VIN- will change the current class of the module. With no resistor fitted the Ag8100 will default to Class 0.
5	VIN-	Direct Input -. This pin connects to the negative (-) output of the input bridge rectifiers.
6	VIN+	Direct Input +. This pin connects to the positive (+) output of the input bridge rectifiers.
7	TGND	Thermal Ground. These pins can be used to dissipate heat from the module.
8		
9		
10	ADJ	Output Adjust. The output voltage is set by connecting an external resistor from this pin to the +VDC pin. See the Output Adjustment section for more information.
11	-VDC	Negative DC Output. These pins provide the negative regulated output from the DC/DC converter.
12		

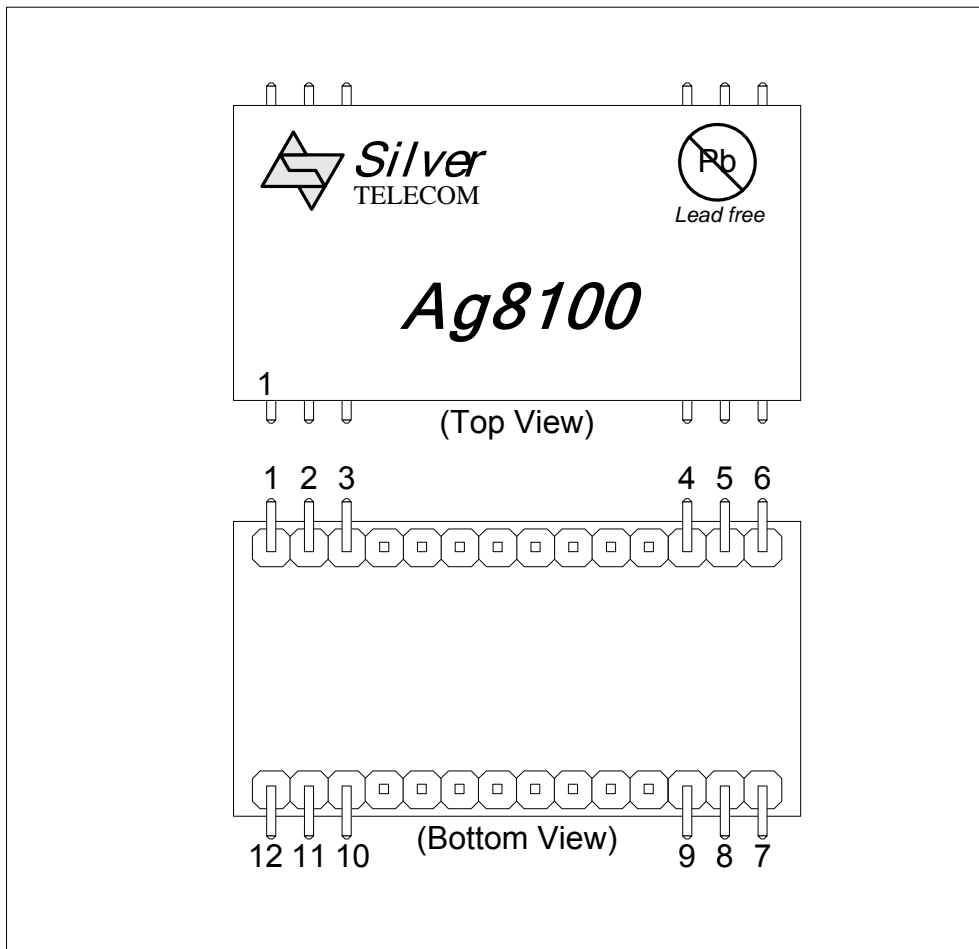

Figure 2: Ag8100 SMT Package Format

5 Functional Description

5.1 Inputs

The Ag8100 has a single input that can be connected to two external bridge rectifiers (see Figure 1). This allows the Ag8100 to be compatible with equipment that use the different power options, see Figure 3. It is important that the PSE does not apply power to both bridge rectifiers at the same time (Refer to IEEE802.3af for more information).

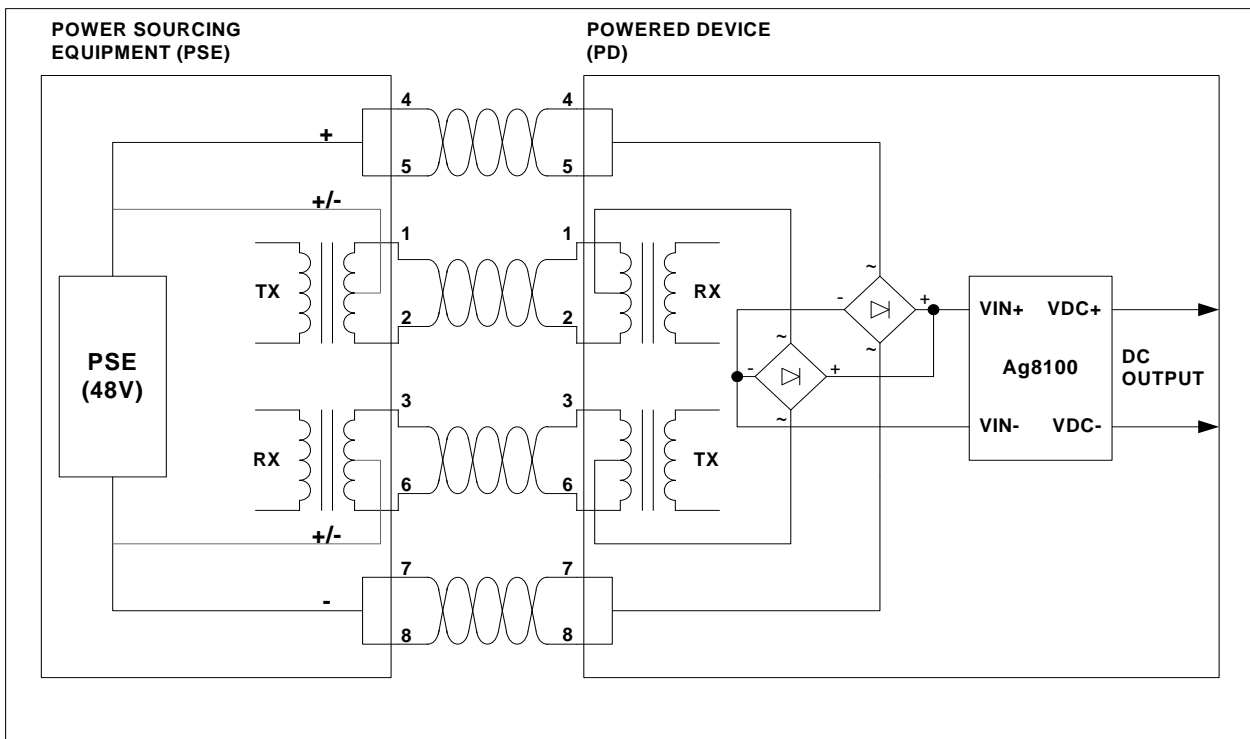

Figure 3: Typical System Diagram

5.2 PD Signature

When the Ag8100 is connected to the Cat 5e cable, it will automatically present a Powered Device (PD) signature to the Power Sourcing Equipment (PSE) or Midspan Equipment, when requested. The equipment will then recognise that a powered device is connected to that line and supply power.

5.3 Isolation

The Ag8100 series conforms to the IEEE 802.3af standard except for the 1500V isolation, which must be done externally. This is usually achieved without additional components, by using a plastic insulated enclosure. Contact Silvertel for further details.

5.4 Power Classification

This is optional from the PSE and is used for power management. The Ag8100 allows the current class to be externally programmed by connecting a resistor between the CP and VIN- pins, see Figure 4. If no resistor is fitted the Ag8100 will default to Class 0, a full list of programming resistor values are shown in Table 2.

CLASS	Programming Resistance (Ohms)	Min Power (W)	Max Power (W)
0	Do not fit	0.44	12.95
1	698R \pm 1%	0.44	3.84
2	383R \pm 1%	3.84	6.49
3	249R \pm 1%	6.49	12.95
4	TBD	Reserved	Reserved

Table 2: Class Programming

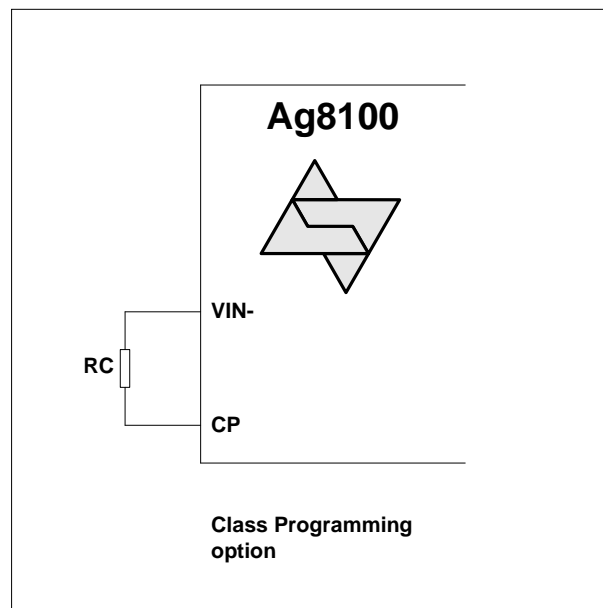

Figure 4: Class Programming Option

5.5 DC/DC Converter

The Ag8100's DC/DC converter provides a non-isolated regulated low ripple and low noise output, that has built-in overload and short-circuit output protection, as well a built-in thermal cut-off - see Table 1: Ordering Information for voltage and power ratings.

Because the Ag8100 series are non-isolated the +VDC output is (internally) connected to the VIN+ input.

5.6 Grounding

If the Ag8100 is supplied from a grounded source (e.g. a standard multi-channel PSE) it is important that the -VDC output is **NOT** connected to ground.

Connecting both input and output to ground will result in a short circuit that will prevent the Ag8100 from operating correctly.

5.7 Output Adjustment

The Ag8100 output voltage is set externally by the RA resistor. If the RA resistor is open circuit (O/C) then the output is set to its maximum voltage. If the RA resistor is a short circuit (S/C) then the output will be set to its minimum voltage. Table 3 below shows the output voltage range of each of the product variants and the values of RA ($\pm 1\%$) required to set the nominal output voltage.

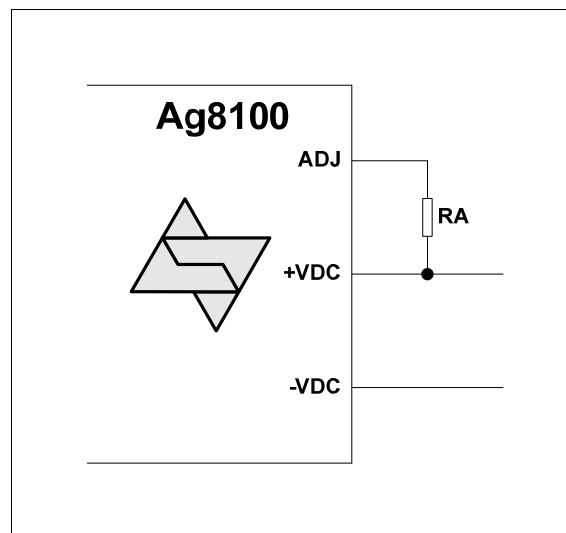

Figure 5: Output Adjustment

Setting the output voltage, connect RA between ADJ and +VDC					
Ag8103		Ag8105		Ag8112	
RA	Output	RA	Output	RA	Output
O/C	4.5V	O/C	7.8V	O/C	14.0V
5K6 $\pm 1\%$	3.3V	3K $\pm 1\%$	5.0V	68K $\pm 1\%$	12.0V
S/C	2.5V	S/C	4.5V	S/C	7.5V

Table 3: Output Adjustment Resistor (RA) Value

*Note: the results in Table 3 are under minimum load conditions

5.8 Typical Connections

The Ag8100 only requires external bridge rectifiers on its input, the RA resistor and a low cost capacitor on its output (a minimum of 470 μ F is recommended) as shown in Figure 6.

The value of C1 will be related to the maximum load step change that the output needs to drive. For example, in an application where the output needs to cope with a 1.8 Amp load step change, a minimum of 1000 μ F should be used. This can be a standard low cost electrolytic and does not need to be a low ESR type.

Figure 6 shows a 16V capacitor that would cover all product variants up to and including the Ag8112, see Table 1: Ordering Information.

The Class programming and the Output Adjust inputs are optional and are provided to give great flexibility to the Ag8100. Further information on using these inputs can be found in sections Power Classification and Output Adjustment.

It is important that the Ag8100 is used with an IEEE802.3af compliant PSE or a power supply with a 400mA current limit.

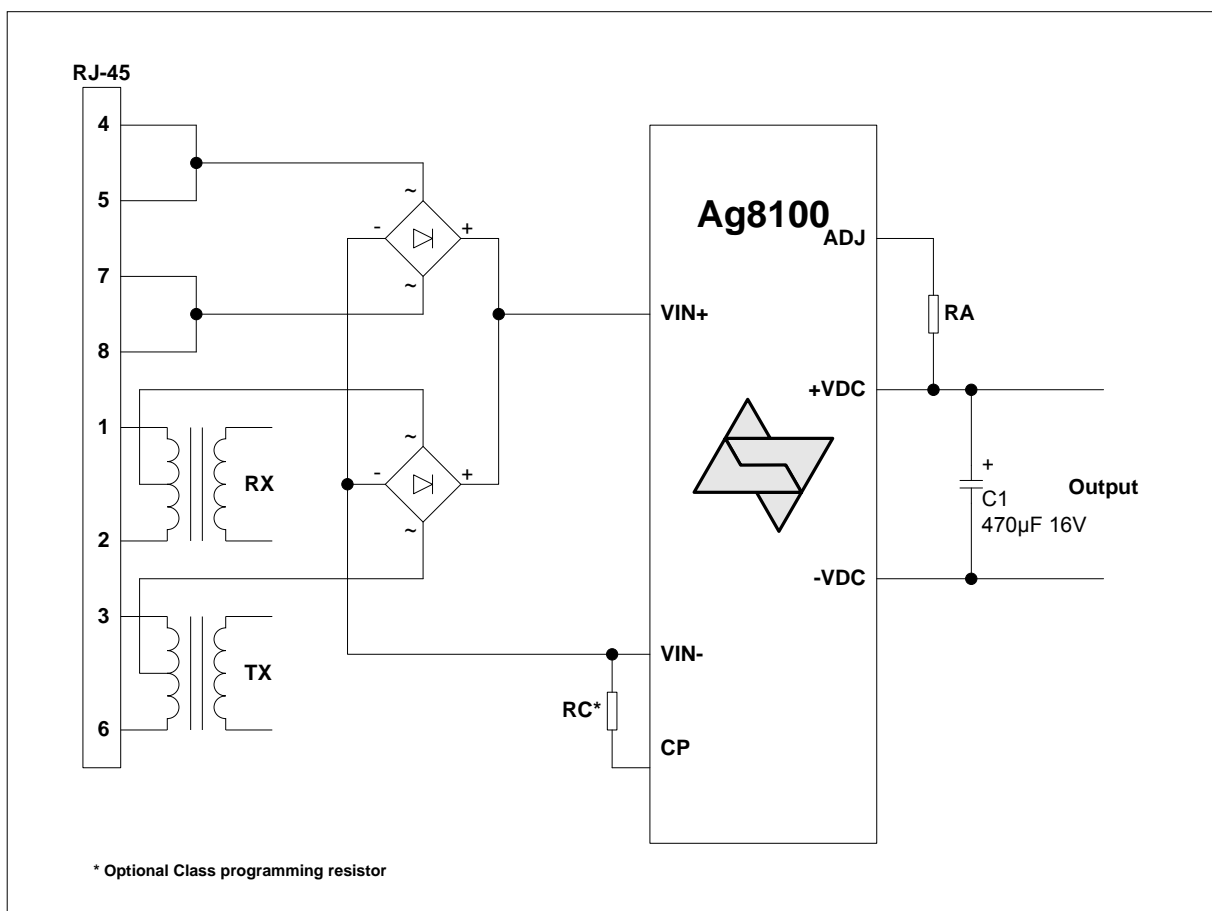

Figure 6: Typical Connection Diagram

6 Typical Application

The Ag8100 can be used in numerous applications. In the example shown in Figure 7, the data outputs from the switch are connected to the inputs of a midspan. The midspan will then add power (to the data) on each output that supports Power over Ethernet (PoE).

In this example port 1 is connected to an ethernet camera and port 2 is connected to a wireless access point, both of these devices have a built-in Ag8100. When the midspan is switched on (or when the device is connected), the midspan will check each output for a PoE signature. On ports 1 and 2 the Ag8100 will identify themselves as PoE enabled devices and the midspan will supply both data and power to these peripherals.

The other ports (shown in this example) will not have a PoE signature and the midspan will only pass the data through to these peripherals. The midspan will continuously monitor each output to see if a PoE enabled device has been added or removed.

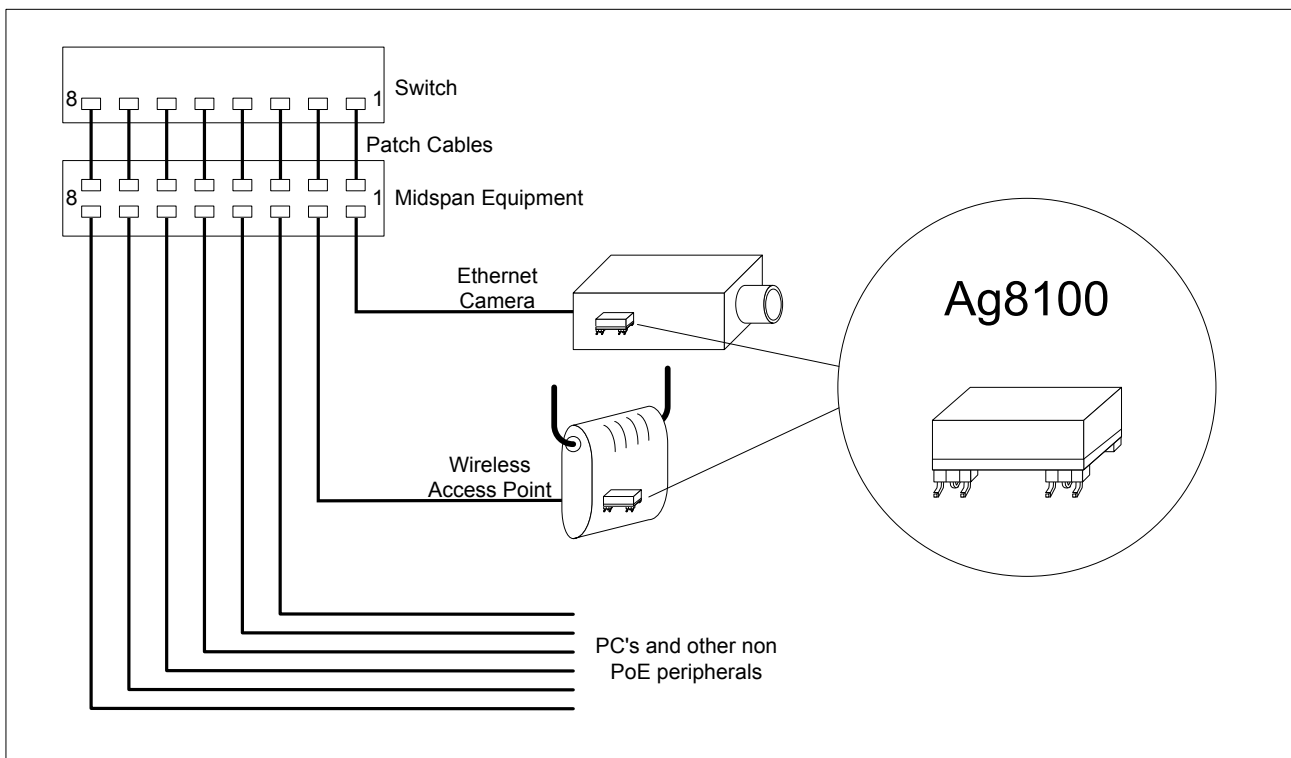

Figure 7: Typical Application

7 Typical Recommendations

Figure 8 gives an example of the tracking needed for the Ag8100. R1, R2 and R3 are optional components, but C1 needs to be positioned close to the output pins of the Ag8100 as possible to minimise the current loop. The thermal performance of the Ag8100 can be improved by increasing the surface area of the track +VDC, -VDC and Thermal Ground.

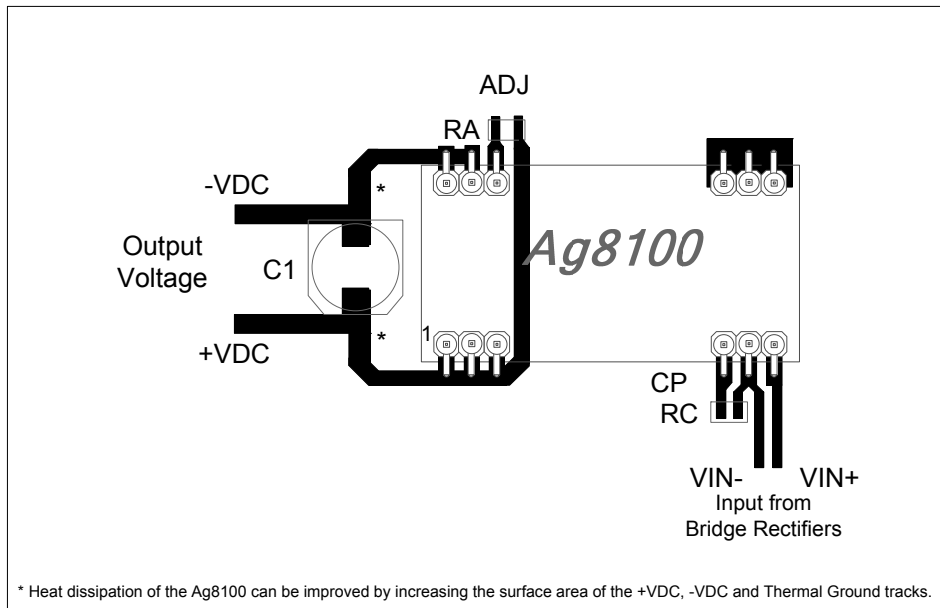

Figure 8: Typical Layout

8 Operating Temperature Range

Because the Ag8100 is a power component, it will generate heat, so it is important that this be taken into consideration at the design stage.

The heart of the Ag8100 is a DC/DC converter, which like any other power supply will generate heat. The amount of heat generated by the module will depend on the load it is required to drive and the input voltage supplied by the PSE. The information shown within this section of datasheet is referenced to a nominal 48Vdc input voltage supplied by the PSE.

The Ag8100 has a maximum ambient operating temperature of 70°C see Figure 10, Figure 11 & Figure 12. These results are in still air without any heatsinking, the performance of the Ag8100 can be improved by forcing the airflow over the part or by using a heatsink (see the Ag8100 application note on heatsinking for more information).

Because each application is different it is impossible to give fixed and absolute thermal recommendations. However it is important that any enclosure used has sufficient ventilation for the Ag8100 and a direct airflow if possible.

One simple method for drawing some of the heat away from the Ag8100 is shown in Figure 9. Power planes connected to the +VDC, -VDC and Thermal Ground pins can be used to draw heat away from the Ag8100. These power planes must be on the outer layer of the PCB on the opposite side of the PCB to the Ag8100.

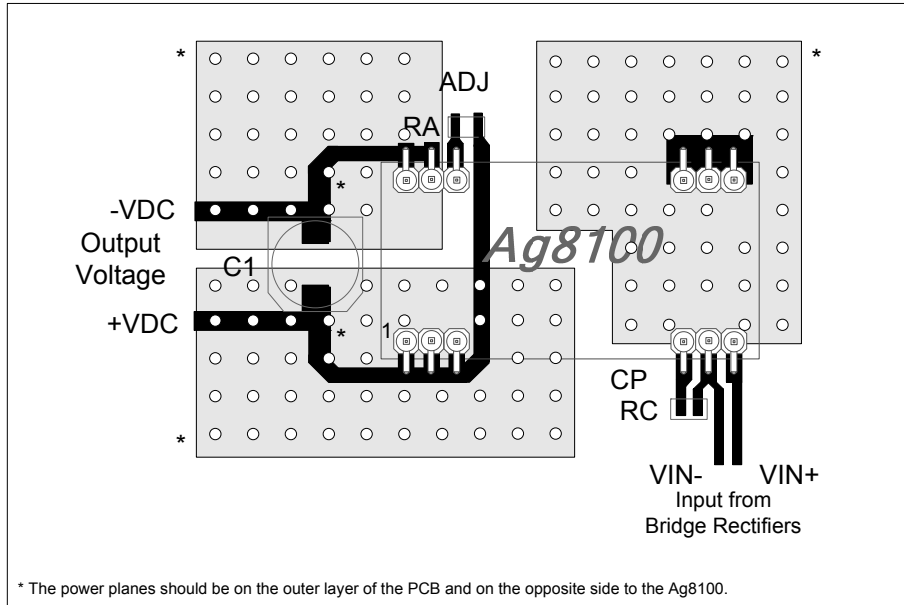

Figure 9: Power Plane Heatsink for Ag8100

Figure 10, Figure 11 & Figure 12 show the maximum ambient temperature under different load conditions. These figure have been recorded in a sealed enclosure (in still air) using a heater element to elevate the ambient temperature (within the enclosure).

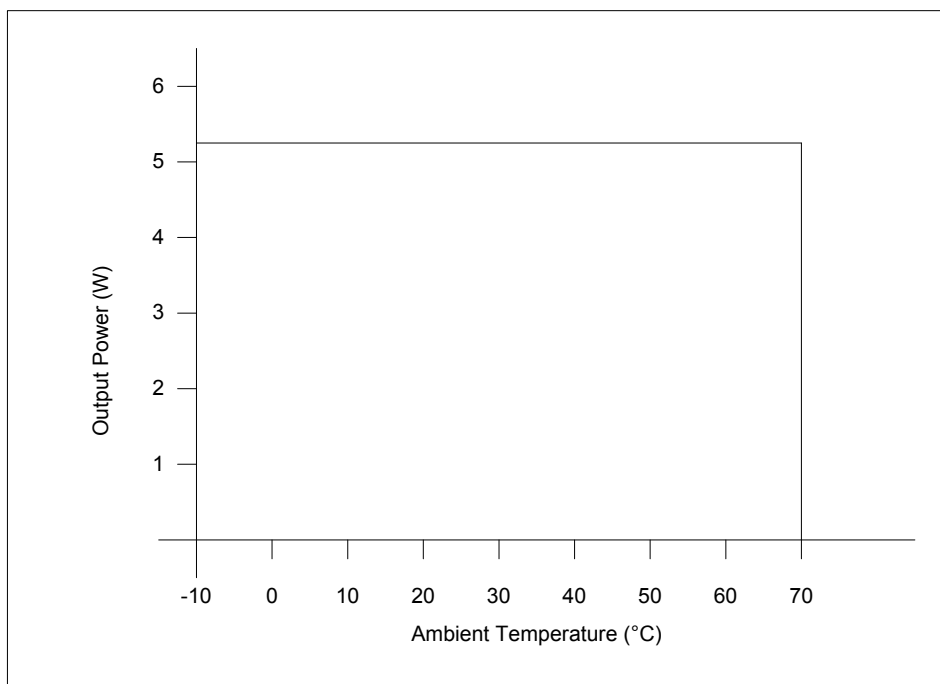

Figure 10: Ag8103 Operating Profile

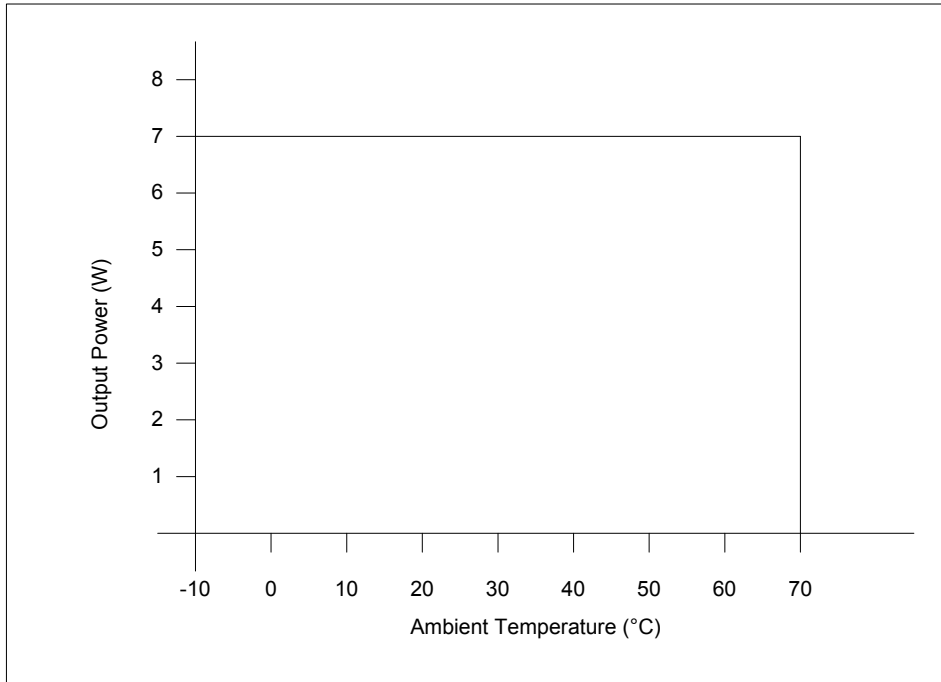

Figure 11: Ag8105 Operating Profile

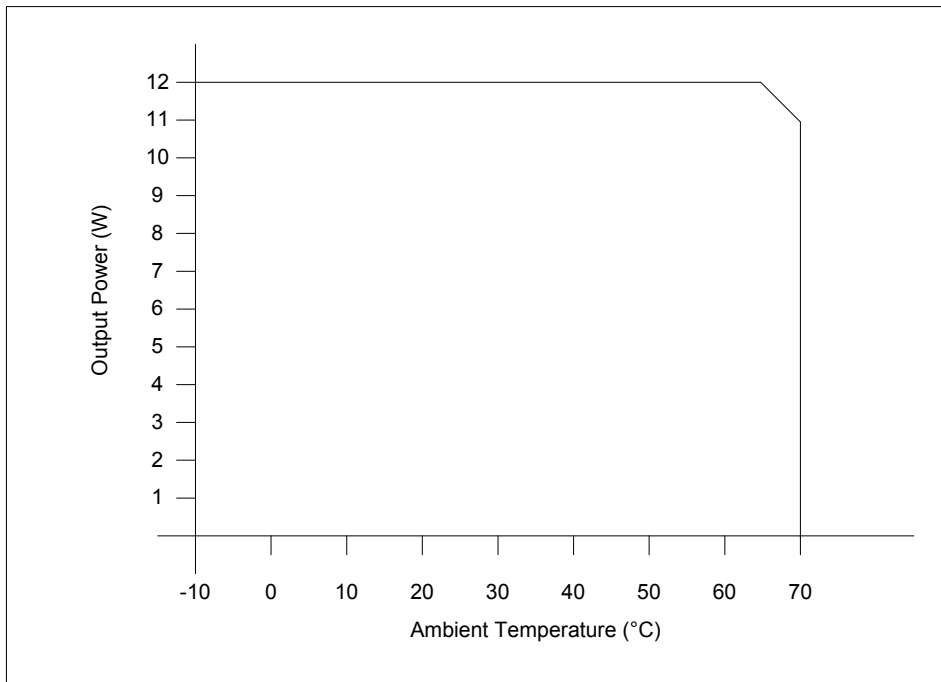

Figure 12: Ag8112 Operating Profile

9 Protection

The Ag8100 has built-in over-current and thermal protection to prevent the module from being damaged if operated beyond its power / temperature specification. If the protection circuit is activated then the DC/DC converter will shut down and will remain off until the input voltage is removed and reapplied. In shut down mode the Ag8100 input current will be less ~1mA, which is below the IEEE802.3af DC MPS (Maintain Power Signature) requirement. If the PSE supports DC MPS, it will detect the low output current and will automatically remove the output power and will return to the signature detection cycle. If the PSE supports AC MPS, then the Ag8100 input will need to be manually removed and reconnected to reset the module. The thermal protection circuit will continue to disable the DC/DC converter until the Ag8100 temperature has cooled sufficiently.

The Ag8100 may be damaged by input voltage transients greater than 80V. If protection from electrostatic discharge (ESD) or other high voltage transients is required, it is recommended that an over-voltage clamping device is fitted between the VIN+ and the VIN- pins. Typically an SMAJ58 will be sufficient; see Apps Note "ANX-POE-Protection".

10 Electrical Characteristics

10.1 Absolute Maximum Ratings*

	Parameter	Symbol	Min	Max	Units
1	DC Supply Voltage	V_{CC}	-0.3	60	V
2	DC Supply Voltage Surge for 1ms	V_{SURGE}	-0.6	80	V
3	Storage Temperature	T_S	-40	+100	$^{\circ}C$

*Exceeding the above ratings may cause permanent damage to the product. Functional operation under these conditions is not implied. Maximum ratings assume free airflow.

10.2 Recommended Operating Conditions

	Parameter	Symbol	Min	Typ	Max	Units
1	Input Supply Voltage	V_{IN}	36	48	57	V
2	Under Voltage Lockout	V_{LOCK}			30	V
3	Operating Temperature	T_{OP}	-10	25	70 \dagger	$T_a / ^{\circ}C$

\dagger See Section Operating Temperature Range

10.3 DC Electrical Characteristics*

	DC Characteristic	Sym	Min	Typ*	Max	Units	Test Comments
1	Output Voltage	V_{OUT}	2.5	3.3	4.5	V	Ag8103
			4.5	5.0	7.8	V	Ag8105
			7.5	12	14	V	Ag8112
2	Output Current ($V_{IN} = 48V$)	I_{OUT}			1.6	A	Ag8103
					1.4	A	Ag8105
					1.0	A	Ag8112
3	Line Regulation $V_{IN} = 36V$ to $57V$ @ max load**	V_{LINE}		1.0		%	Ag8103
				0.8		%	Ag8105
				0.4		%	Ag8112
4	Load Regulation min to max load ($V_{IN} = 48V$)**	V_{LOAD}		4.5		%	Ag8103
				2.6		%	Ag8105
				1.0		%	Ag8112
5	Output Ripple and Noise @ Max load \dagger	V_{RN}		90 150 64		mVp-p mVp-p mVp-p	Ag8103 Ag8105 Ag8112
6	Minimum Load	R_{LOAD}		150		mA	for specified regulation \ddagger
7	Short-Circuit Duration	T_{SC}			∞	sec	Continuous @ $50^{\circ}C$, $V_{IN}=48V$
8	Efficiency @ 100% Load, $V_{IN}=48V$	EFF		71		%	Ag8103
				79		%	Ag8105
				86		%	Ag8112

*Typical figures are at $25^{\circ}C$ with a nominal 48V supply after 5 minutes and are for design aid only. Not Guaranteed

**After 5 minutes

\dagger The output ripple and noise can be reduced with an external filter, see application note.

\ddagger Can be used with no load at reduced voltage regulation.

11 Package

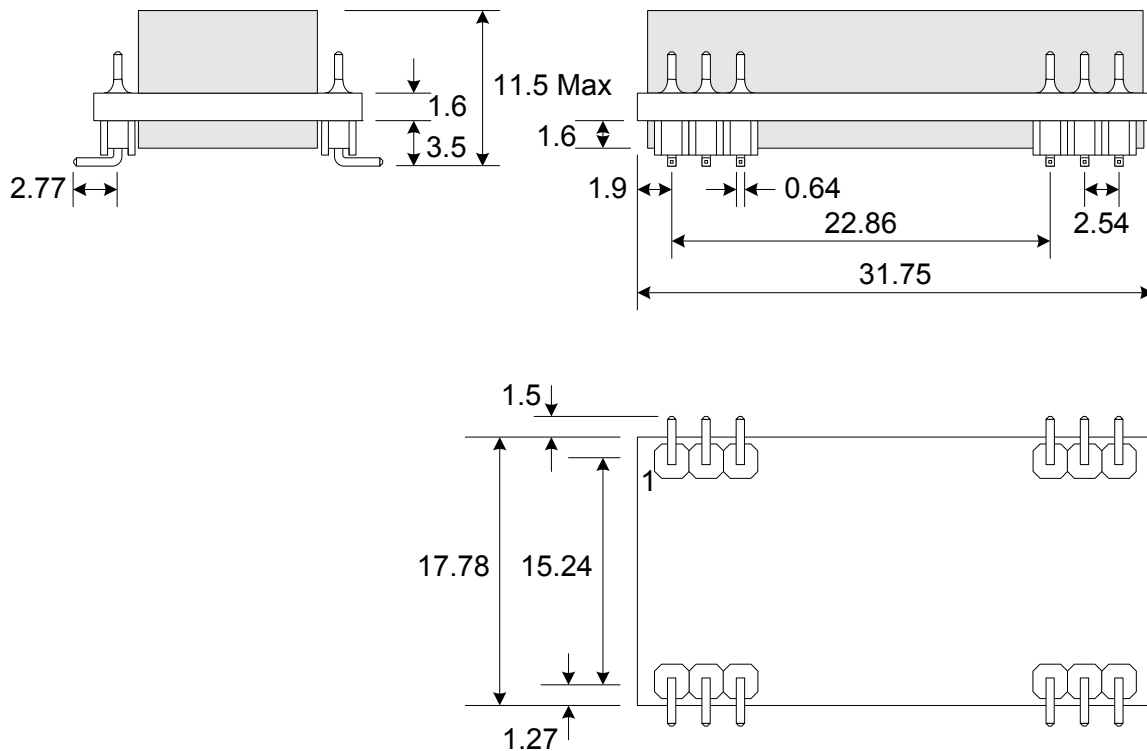

All dimensions are in mm +/-0.127mm and are nominal values, unless otherwise stated.

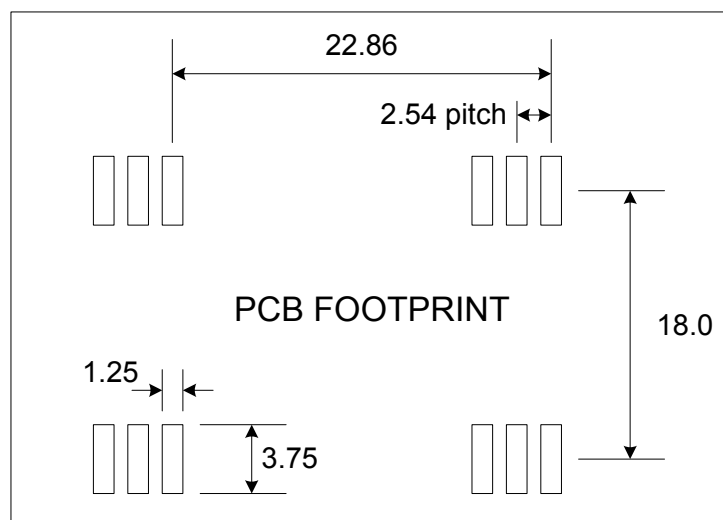

Information published in this datasheet is believed to be correct and accurate. Silver Telecom assumes no liability for errors which may occur or for liability otherwise arising out of use of this information or infringement of patents which may occur as a result of such use. No license is granted by this document under patents owned by Silver Telecom or licensed from third parties by Silver Telecom. The products, their specification and information appearing in this document are subject to change by Silver Telecom without notice.