



**Ag103 Evaluation Board
User Manual**

Rev 1.0 – October 2015

1 Table of Contents

1	Table of Contents	1
2	Table of Figures	1
3	Introduction	2
4	Board Description	2
4.1	<i>Input</i>	2
4.2	<i>Output</i>	3
4.3	<i>Capacity Selection</i>	3
4.4	<i>Simulated Thermal Offset</i>	4
4.5	<i>Status Output</i>	4
4.5.1	Mode 0 – Bulk Charge Operation	5
4.5.2	Mode 1– Float Charge	5
4.5.3	Mode 2 – Over Current	5
4.5.4	Mode 3 – Over Temperature	5
4.5.5	Mode 4 – Disconnected battery	5
4.5.6	Mode 5 - Input Voltage Removed/ No Solar Power	6
5	Using the Board	6
6	EVALAg103 Evaluation Board Schematic	7

2 Table of Figures

Figure 1:	Board Layout.....	2
Figure 2:	Capacity selection link.....	3
Figure 3:	Example set-up	6
Figure 4:	EVALAg103 R1 Schematic	7

3 Introduction

This manual is a guide to using the “EVALAg103” (Rev R1) evaluation board with our Ag103 Sealed Lead Acid (SLA) solar battery charger module. The EVALAg103 evaluation board can be powered by either a 21V open circuit solar panel, or a bench power supply with a range of 9V to 36V. This will charge SLA batteries with a capacity between 1.2Ah and 12Ah.

4 Board Description

4.1 Input

The input power is supplied to the board through connector J1 or J2 (see Figure 1). J1 is a standard 2.5mm DC10 connector with the centre pin of the connector being positive and the outer is negative. J2 is a screw terminal with pin 1 as the positive input. The input current can be measured by removing LK1 and connecting an ammeter across these pins.

LED1 will be illuminated when the input supply is ON.

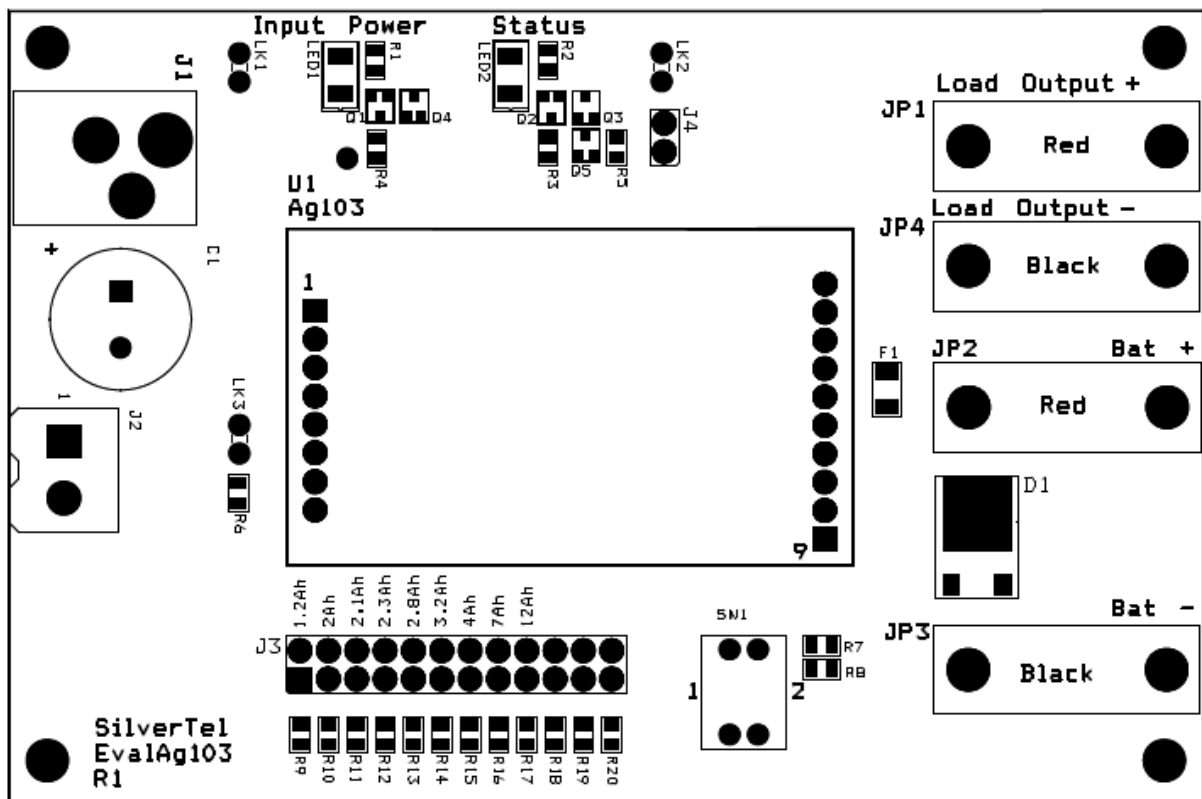

Figure 1: Board Layout

4.2 Output

The output connections to the SLA battery are made through JP2 (positive) and JP3 (negative) with added protection of F1 as a 8A fuse and D1 as a 10A diode, to protect an over current or short for either the load or battery. The Load Output connections are available through JP1 (positive) and JP4 (negative).

4.3 Capacity Selection

The EVALAg103 evaluation board can set the Ag103 capacity from 1.2Ah to 12Ah by setting the corresponding jumper link on J3 (see Figure 2 and Table 1).

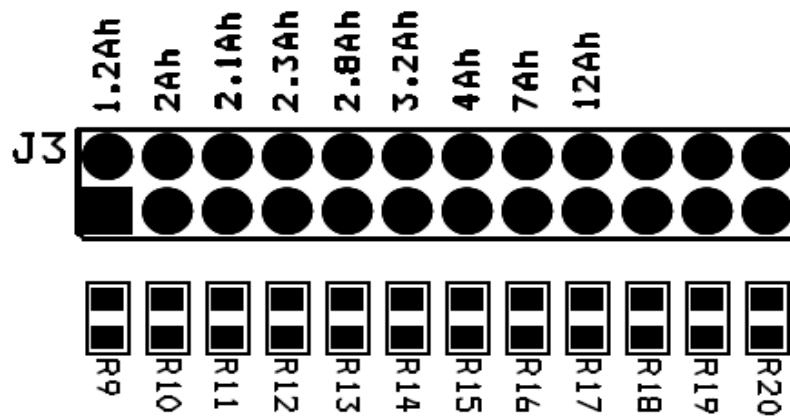

Figure 2: Capacity selection link

J6 Resistor Selection	Battery Capacity (Ah)	R _{CS} Resistance (Ohms)*	Min Input Voltage (V)	Bulk Charge Current Limit (A) ±10%
R9	1.2	1K ±1%	9	0.3
R10	2	2K ±1%	9	0.5
R11	2.1	3K ±1%	9	0.525
R12	2.3	3K9 ±1%	9	0.575
R13	2.8	4K7 ±1%	9	0.7
R14	3.2	6K2 ±1%	12	0.8
R15	4	6K8 ±1%	12	1
R16	7	7K5 ±1%	12	1.2
R17	12	9K1 ±1%	12	1.2

Table 1: Output Connections

Note: to prevent damaging the battery it is important that the correct value of RCS is set. If the selector link is not fitted, then the Ag103 will default to 1.2Ah capacity.

4.4 Simulated Thermal Offset

During Float charge SW1 can be used to demonstrate how the voltage changes to compensate for the change in battery temperature if an appropriate thermistor is fitted. With both switch positions open, the Ag103 will default to a 25°C ambient charge voltage.

When switch No. 1 is closed, placing R7 (20K) to ground, this will simulate a battery temperature higher than 25°C and the output voltage will decrease (this response will be slow when the Ag103 is float charging).

When switch No. 2 is closed, placing R8 (220K) to ground, this will simulate a battery temperature lower than 25°C and the output voltage will increase.

When both switches are closed this will simulate a battery temperature higher than 50°C, the output will switch OFF and the Status LED (2) will flash in mode 3. Opening one or both switches will return the Ag103 to its normal charge mode.

4.5 Status Output

The Ag103 has a status indication output pin 'STAT'; that can be either connected to a μ -controller input for full status monitoring, via connector J4, or can be used with an LED as an indicator by fitting a link on LK2.

If LK2 is fitted then LED 2 will be illuminated with the sequences detailed below and shown in Table 2: -

Mode	Status Mode	STAT Output
0	Bulk Charge Operation	Steady State 'Logic 1'
1	Float Charge	50% 'Logic 1' 50% 'Logic 0'
2	Over Current Error	1 Pulse
3	Over Temperature Error	2 Pulses
4	Disconnected Battery Error	3 Pulses
5	Input Voltage Removed / No Solar Power	Steady State 'Logic 0'

Table 2: STAT Output Conditions

*For further information on the timing of the STAT output please see Figure 8 of the Ag103 datasheet.

4.5.1 Mode 0 – Bulk Charge Operation

Once the Ag103 has checked the battery capacity and sees a 12V battery connected it will power up and the 'STAT' pin will output a steady state 'logic 1'.

The Ag103 will continue to output this state until the battery has reached it's 80% charge before switching to float charge and enters Mode 1.

4.5.2 Mode 1– Float Charge

After the battery has reached it's 80% charge the Ag103 will change it's charging status to float charge by dropping it's terminal voltage down to ~13.65V. The 'STAT' pin will drop to a logic 0 for 1s and then back to a logic 1 for 1s. This cycle will repeat itself over the period of its float charge.

4.5.3 Mode 2 – Over Current

If an output over current condition is detected, the Ag103 will shutdown its DC-DC converter and will go into Mode 2. The STAT pin will drop to a logic 0 for 100ms, followed by a logic 1 for 100ms before returning to a logic 0. The Ag103 will then reset and wait 2 seconds before re-attempting to power up. If the over current is still there when trying to power up, the Ag103 will immediately shut back down and repeat the process. Once the over current has been removed the Ag103 will return to Mode 0 (bulk charge operation).

4.5.4 Mode 3 – Over Temperature

If a battery over temperature condition occurs, the Ag103 will shutdown its DC-DC converter to protect the battery and enter Mode 3. The STAT pin will drop to a logic 0 for 100ms before generating two logic 1 pulses, with a 100ms mark and 100ms space. This will repeat over a 2s period until the battery temperature has dropped below 50°C (the maximum operating temperature). Once the battery temperature has dropped below 50°C the Ag103 will return to Mode 0 (bulk charge operation).

4.5.5 Mode 4 – Disconnected battery

If the battery is disconnected or there is no battery present at power up, the Ag103 will shutdown its DC-DC converter, go into Mode 4 and output three 100ms logic 1 pulses, with a 100ms mark and 100ms space. This will repeat over a 2s period until a 12V battery is connected. When a 12V battery is connected the Ag103 will go into Mode 0 (bulk charge operation).

4.5.6 Mode 5 - Input Voltage Removed/ No Solar Power

When the input voltage is removed or the solar panel can no longer provide any power to the Ag103, the STAT pin will output a logic 0 until power has been reconnected or the panel can provide enough power to charge the connected battery.

5 Using the Board

Figure 3 shows an example set-up using the Ag103 to charge a 12Ah SLA battery from a solar panel. For a 12Ah battery the J3 link is set to the R17 position.

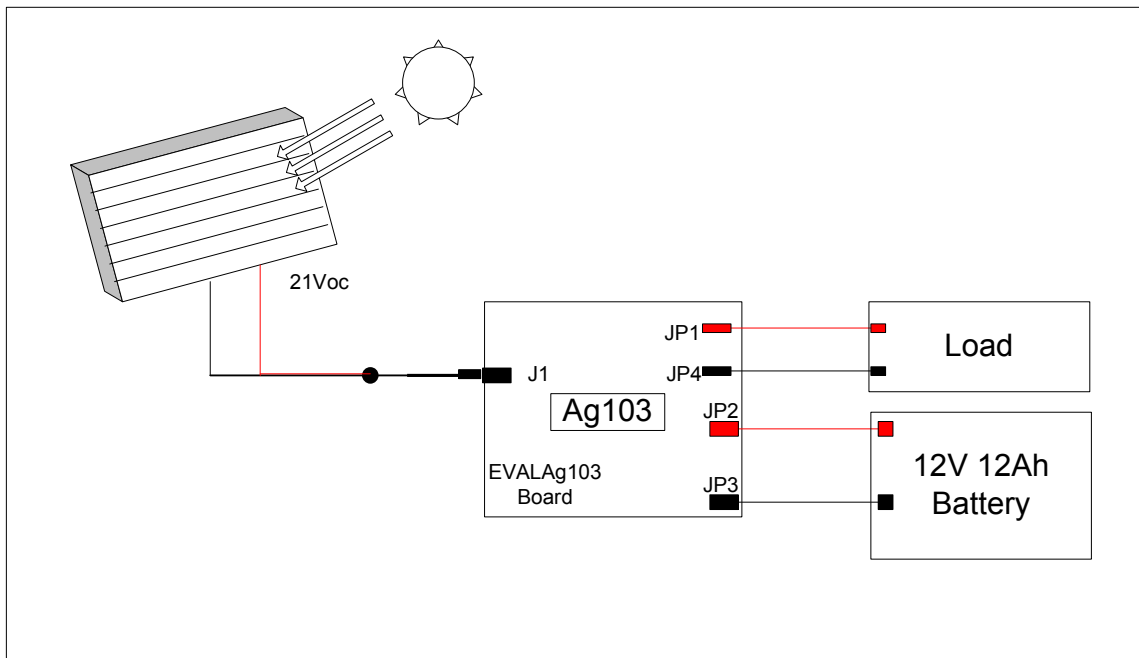

Figure 3: Example set-up

6 EVALAg103 Evaluation Board Schematic

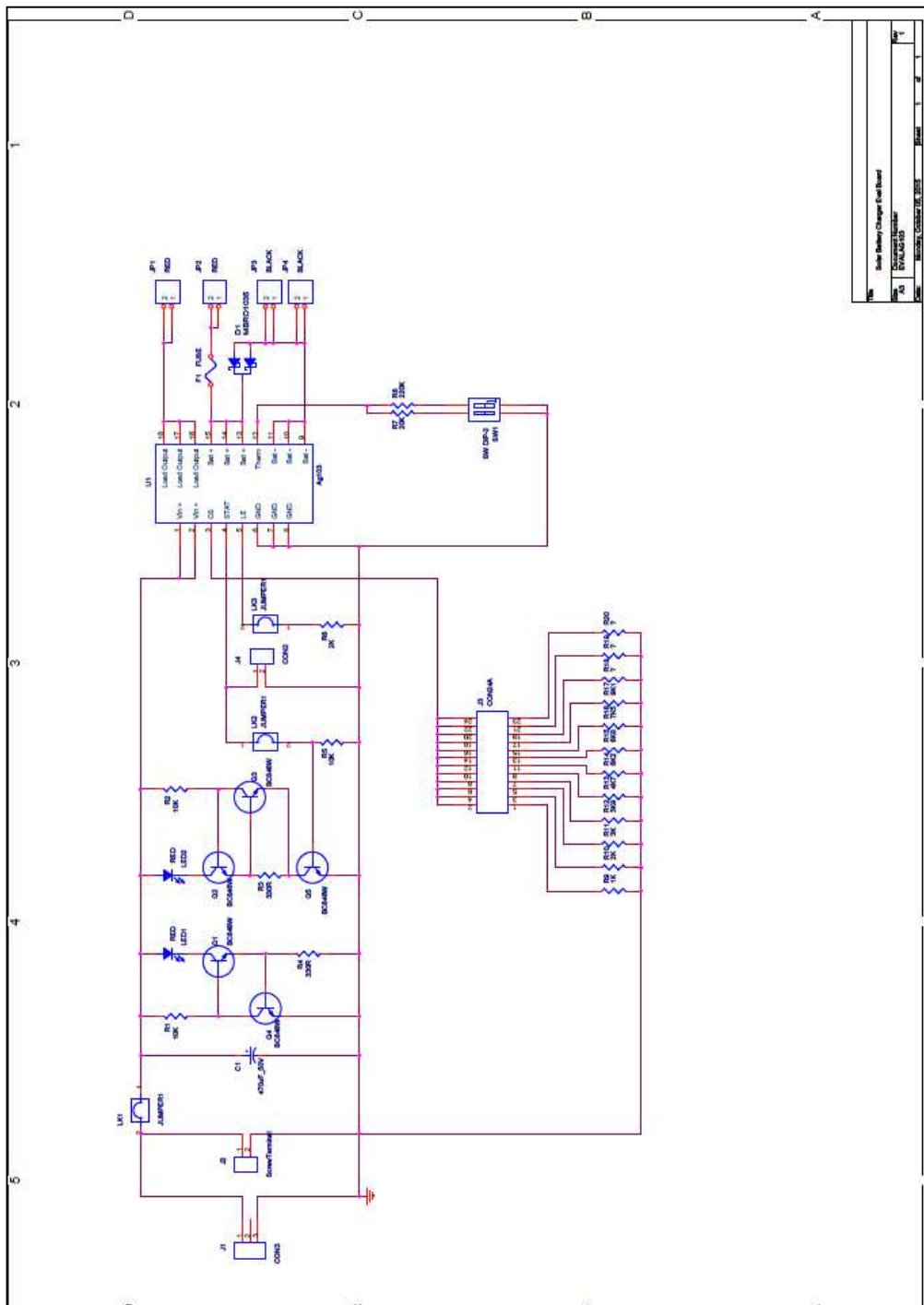

Figure 4: EVALAg103 R1 Schematic